

Dell™ DX6000 Systems

# Hardware Owner's Manual



# Notes, Cautions, and Warnings



**NOTE:** A NOTE indicates important information that helps you make better use of your computer.



**CAUTION:** A CAUTION indicates potential damage to hardware or loss of data if instructions are not followed.



**WARNING:** A WARNING indicates a potential for property damage, personal injury, or death.

---

**Information in this document is subject to change without notice.**

© 2010 Dell Inc. All rights reserved.

Reproduction of these materials in any manner whatsoever without the written permission of Dell Inc. is strictly forbidden.

Trademarks used in this text: *Dell* and the *DELL* logo are trademarks of Dell Inc.; *Microsoft* and *Windows Server* are either trademarks or registered trademarks of Microsoft Corporation in the United States and/or other countries.

Other trademarks and trade names may be used in this document to refer to either the entities claiming the marks and names or their products. Dell Inc. disclaims any proprietary interest in trademarks and trade names other than its own.

# Contents

1	About Your System . . . . .	11
	<b>Accessing System Features During Startup . . . . .</b>	<b>11</b>
	<b>Front-Panel Features and Indicators . . . . .</b>	<b>12</b>
	<b>LCD Panel Features . . . . .</b>	<b>14</b>
	Home Screen . . . . .	15
	Setup Menu . . . . .	16
	View Menu . . . . .	16
	<b>Hard-Drive Indicator Patterns for RAID . . . . .</b>	<b>18</b>
	<b>Back Panel Features and Indicators . . . . .</b>	<b>19</b>
	<b>Power Indicator Codes . . . . .</b>	<b>21</b>
	<b>NIC Indicator Codes . . . . .</b>	<b>22</b>
	<b>LCD Status Messages . . . . .</b>	<b>23</b>
	Viewing Status Messages . . . . .	23
	Removing LCD Status Messages . . . . .	23
	<b>System Messages . . . . .</b>	<b>38</b>
	<b>Warning Messages . . . . .</b>	<b>55</b>
	<b>Diagnostics Messages . . . . .</b>	<b>55</b>
	<b>Alert Messages . . . . .</b>	<b>56</b>
	<b>Other Information You May Need . . . . .</b>	<b>56</b>

2	Using the System Setup Program and UEFI Boot Manager . . . . .	57
	<b>Choosing the System Boot Mode . . . . .</b>	<b>57</b>
	<b>Entering the System Setup Program . . . . .</b>	<b>58</b>
	Responding to Error Messages . . . . .	58
	Using the System Setup Program Navigation Keys . . . . .	58
	<b>System Setup Options . . . . .</b>	<b>59</b>
	Main Screen . . . . .	59
	Memory Settings Screen . . . . .	61
	Processor Settings Screen . . . . .	62
	SATA Settings Screen . . . . .	63
	Boot Settings Screen . . . . .	63
	Integrated Devices Screen . . . . .	64
	PCI IRQ Assignments Screen . . . . .	65
	Serial Communication Screen . . . . .	66
	Embedded Server Management Screen . . . . .	67
	Power Management Screen . . . . .	67
	System Security Screen . . . . .	68
	Exit Screen . . . . .	70
	<b>Entering the UEFI Boot Manager . . . . .</b>	<b>70</b>
	Using the UEFI Boot Manager Navigation Keys . . . . .	71
	UEFI Boot Manager Screen . . . . .	71
	UEFI Boot Settings Screen . . . . .	72
	System Utilities Screen . . . . .	72
	<b>System and Setup Password Features . . . . .</b>	<b>73</b>
	Using the System Password . . . . .	73
	Using the Setup Password . . . . .	75

<b>iDRAC Configuration Utility</b> . . . . .	<b>76</b>
Entering the iDRAC Configuration Utility . . . . .	77
<b>3 Installing System Components</b> . . . . .	<b>79</b>
<b>Recommended Tools</b> . . . . .	<b>79</b>
<b>Inside the System</b> . . . . .	<b>79</b>
<b>Front Bezel (Optional)</b> . . . . .	<b>81</b>
Removing the Front Bezel . . . . .	81
Installing the Front Bezel . . . . .	82
<b>Information Tag</b> . . . . .	<b>82</b>
Removing the Information Tag . . . . .	82
Replacing the Information Tag . . . . .	82
<b>Opening and Closing the System</b> . . . . .	<b>83</b>
Opening the System . . . . .	83
Closing the System . . . . .	83
<b>Hard Drives</b> . . . . .	<b>84</b>
Removing a Hard-Drive Blank . . . . .	85
Installing a Hard-Drive Blank . . . . .	86
Removing a Hot-Swap Hard Drive . . . . .	86
Installing a Hot-Swap Hard Drive . . . . .	86
Removing a Hard Drive From a Hard-Drive Carrier . . . . .	87
Installing a Hard Drive Into a Hard-Drive Carrier . . . . .	88
<b>Power Supplies</b> . . . . .	<b>90</b>
Removing a Power Supply . . . . .	90
Replacing a Power Supply . . . . .	91
Removing the Power Supply Blank . . . . .	92

Installing the Power Supply Blank . . . . .	92
<b>Internal SD Module . . . . .</b>	<b>92</b>
Installing the Internal SD Module . . . . .	92
Removing the Internal SD Module . . . . .	94
<b>Internal SD Flash Card . . . . .</b>	<b>94</b>
Installing the Internal SD Flash Card . . . . .	94
Removing the Internal SD Flash Card . . . . .	95
<b>Internal USB Memory Key . . . . .</b>	<b>95</b>
<b>Internal USB Cable . . . . .</b>	<b>97</b>
Removing the Internal USB Cable . . . . .	97
Installing the Internal USB Cable . . . . .	97
<b>Integrated Dell Remote Access Controller 6 (iDRAC6) Enterprise Card (Optional) . . . . .</b>	<b>98</b>
Installing an iDRAC6 Enterprise Card . . . . .	98
Removing an iDRAC6 Enterprise Card . . . . .	99
<b>VFlash Media (Optional) . . . . .</b>	<b>100</b>
<b>NIC Hardware Key . . . . .</b>	<b>101</b>
<b>Cooling Shroud . . . . .</b>	<b>102</b>
Removing the Cooling Shroud . . . . .	103
Installing the Cooling Shroud . . . . .	104
<b>Cooling Fans . . . . .</b>	<b>105</b>
Removing a Cooling Fan . . . . .	105
Replacing a Cooling Fan . . . . .	106
Removing the Fan Bracket . . . . .	107
Replacing the Fan Bracket . . . . .	108

<b>Optical Drive</b> . . . . .	<b>109</b>
Removing the Optical Drive . . . . .	109
Installing the Optical Drive . . . . .	109
<b>Integrated Storage Controller Card</b> . . . . .	<b>112</b>
Removing the Integrated Storage Controller Card . . . . .	113
Installing the Integrated Storage Controller Card . . . . .	113
<b>RAID Battery</b> . . . . .	<b>116</b>
Removing a RAID Battery . . . . .	116
Installing a RAID Battery . . . . .	116
<b>Cable Routing</b> . . . . .	<b>118</b>
Removing the Cable Retention Bracket . . . . .	118
Installing the Cable Retention Bracket . . . . .	119
<b>Expansion Cards and Expansion-Card Risers</b> . . . . .	<b>120</b>
Expansion Card Installation Guidelines . . . . .	120
Installing an Expansion Card . . . . .	121
Removing an Expansion Card . . . . .	123
Removing Expansion-Card Riser 1 . . . . .	124
Replacing Expansion-Card Riser 1 . . . . .	125
Removing Expansion-Card Riser 2 . . . . .	126
Replacing Expansion-Card Riser 2 . . . . .	127
Removing Expansion-Card Riser 2 From the Expansion-Card Bracket . . . . .	128
Replacing the Riser 2 Board on the Expansion-Card Bracket . . . . .	130
<b>System Memory</b> . . . . .	<b>130</b>
General Memory Module Installation Guidelines . . . . .	131
Mode-Specific Guidelines . . . . .	132
Installing Memory Modules . . . . .	135

Removing Memory Modules . . . . .	137
<b>Processors . . . . .</b>	<b>138</b>
Removing a Processor . . . . .	138
Installing a Processor . . . . .	141
<b>System Battery . . . . .</b>	<b>143</b>
Replacing the System Battery . . . . .	143
<b>Control Panel Assembly . . . . .</b>	<b>145</b>
Removing the Control Panel Display Module . . . . .	145
Installing the Control Panel Display Module . . . . .	145
Removing the Control Panel Board . . . . .	147
Installing the Control Panel Board . . . . .	147
<b>SAS Backplane (Service Only Procedure) . . . . .</b>	<b>148</b>
Removing the SAS Backplane . . . . .	148
Installing a SAS Backplane . . . . .	150
<b>System Board . . . . .</b>	<b>150</b>
Removing the System Board . . . . .	150
Installing the System Board . . . . .	152
<b>4 Troubleshooting Your System . . . . .</b>	<b>155</b>
<b>Safety First—For You and Your System . . . . .</b>	<b>155</b>
<b>Troubleshooting System Startup Failure . . . . .</b>	<b>155</b>
<b>Troubleshooting External Connections . . . . .</b>	<b>155</b>
<b>Troubleshooting the Video Subsystem . . . . .</b>	<b>156</b>
<b>Troubleshooting a USB Device . . . . .</b>	<b>156</b>
<b>Troubleshooting a Serial I/O Device . . . . .</b>	<b>157</b>



<b>Troubleshooting a NIC</b> . . . . .	<b>157</b>
<b>Troubleshooting a Wet System</b> . . . . .	<b>158</b>
<b>Troubleshooting a Damaged System</b> . . . . .	<b>159</b>
<b>Troubleshooting the System Battery</b> . . . . .	<b>160</b>
<b>Troubleshooting Power Supplies</b> . . . . .	<b>161</b>
<b>Troubleshooting System Cooling Problems</b> . . . . .	<b>161</b>
<b>Troubleshooting a Fan</b> . . . . .	<b>162</b>
<b>Troubleshooting System Memory</b> . . . . .	<b>163</b>
<b>Troubleshooting an Internal SD Card</b> . . . . .	<b>165</b>
<b>Troubleshooting an Internal USB Memory Key</b> . . . . .	<b>166</b>
<b>Troubleshooting an Optical Drive</b> . . . . .	<b>167</b>
<b>Troubleshooting a Hard Drive</b> . . . . .	<b>168</b>
<b>Troubleshooting a Storage Controller</b> . . . . .	<b>169</b>
<b>Troubleshooting Expansion Cards</b> . . . . .	<b>170</b>
<b>Troubleshooting the Processor</b> . . . . .	<b>172</b>
<b>5 Running the System Diagnostics</b> . . . . .	<b>173</b>
<b>Using Online Diagnostics</b> . . . . .	<b>173</b>
<b>Embedded System Diagnostics Features</b> . . . . .	<b>173</b>
<b>When to Use the Embedded System Diagnostics</b> . . . . .	<b>174</b>
<b>Running the Embedded System Diagnostics</b> . . . . .	<b>174</b>
<b>System Diagnostics Testing Options</b> . . . . .	<b>174</b>

<b>Using the Custom Test Options</b> . . . . .	<b>175</b>
Selecting Devices for Testing . . . . .	175
Selecting Diagnostics Options . . . . .	175
Viewing Information and Results . . . . .	176
<b>6 Jumpers and Connectors</b> . . . . .	<b>177</b>
<b>System Board Jumpers</b> . . . . .	<b>177</b>
<b>System Board Connectors</b> . . . . .	<b>180</b>
<b>SAS Backplane Board Connectors</b> . . . . .	<b>183</b>
<b>Expansion-Card Riser-Board Components and     PCIe Buses</b> . . . . .	<b>184</b>
<b>Disabling a Forgotten Password</b> . . . . .	<b>186</b>
<b>7 Getting Help</b> . . . . .	<b>189</b>
<b>Contacting Dell</b> . . . . .	<b>189</b>
<b>Index</b> . . . . .	<b>195</b>

# About Your System

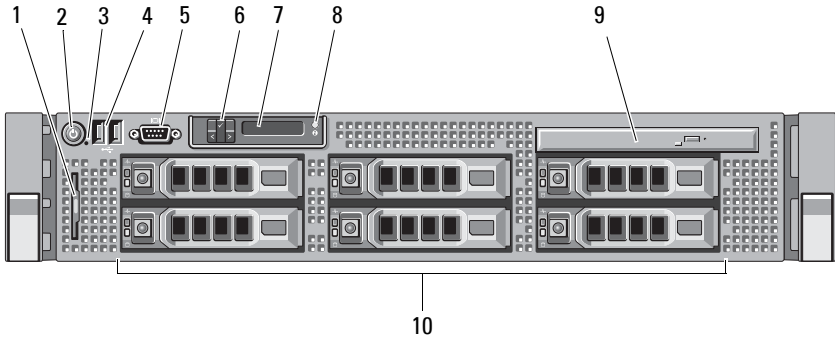
## Accessing System Features During Startup

The following keystrokes provide access to system features during startup.





Keystroke	Description
<F2>	Enters the System Setup program. See "Using the System Setup Program and UEFI Boot Manager" on page 57.
<F10>	Enters System Services, which opens the Unified Server Configurator from which you can access utilities such as system diagnostics. For more information, see the Unified Server Configurator user documentation. <b>NOTE:</b> Some Unified Server Configurator processing, such as software updates, can cause virtual devices to be created that at times may appear as USB devices attached to your system. These connections are both secure and temporary, and can be disregarded.
<F11>	Enters the BIOS Boot Manager or the UEFI Boot Manager, depending on your system's boot configuration. See "Using the System Setup Program and UEFI Boot Manager" on page 57.
<F12>	Enters PXE boot, if enabled.
<Ctrl><E>	Enters the iDRAC Configuration Utility, which allows access to the system event log (SEL) and configuration of remote access to the system. For more information, see the iDRAC user documentation.
<Ctrl><R>	Enters the PERC configuration utility. For more information, see the PERC card documentation.
<Ctrl><S>	Enters the utility to configure NIC settings for PXE boot. For more information, see the documentation for your embedded NIC.


# Front-Panel Features and Indicators

Figure 1-1. Front-Panel Features and Indicators



Item	Indicator, Button, or Connector	Icon	Description
1	Information tag		A slide-out label panel for system information including the Express Service tag, Embedded NIC1 MAC address, and iDRAC6 Enterprise card MAC address.

Item	Indicator, Button, or Connector	Icon	Description
2	Power-on indicator, power button		<p>The power-on indicator lights when the system power is on.</p> <p>The power button controls the DC power supply output to the system. When the system bezel is installed, the power button is not accessible.</p> <p><b>NOTE:</b> When powering on the system, the video monitor can take up to 25 seconds to display an image, depending on the amount of memory installed in the system.</p> <p><b>NOTE:</b> On ACPI-compliant operating systems, turning off the system using the power button causes the system to perform a graceful shutdown before power to the system is turned off.</p> <p><b>NOTE:</b> To force an ungraceful shutdown, press and hold the power button for five seconds.</p>
3	NMI button		<p>Used to troubleshoot software and device driver errors when using certain operating systems. This button can be pressed using the end of a paper clip.</p> <p>Use this button only if directed to do so by qualified support personnel or by the operating system's documentation.</p>
4	USB connectors (2)		<p>Connects USB devices to the system. The ports are USB 2.0-compliant.</p>
5	Video connector		<p>Connects a monitor to the system.</p>
6	LCD menu buttons		<p>Allows you to navigate the control panel LCD menu.</p>

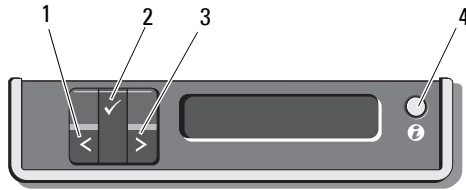
Item	Indicator, Button, or Connector	Icon	Description
7	LCD panel		<p>Provides system ID, status information, and system error messages.</p> <p>The LCD lights blue during normal system operation. The LCD lights amber when the system needs attention, and the LCD panel displays an error code followed by descriptive text.</p> <p><b>NOTE:</b> If the system is connected to AC power and an error has been detected, the LCD lights amber regardless of whether the system has been powered on.</p>
8	System identification button		<p>The identification buttons on the front and back panels can be used to locate a particular system within a rack. When one of these buttons is pushed, the LCD panel on the front and the system status indicator on the back flash blue until one of the buttons is pushed again.</p>
9	Optical drive		<p>One slim-line SATA DVD-ROM drive or DVD+RW drive.</p> <p><b>NOTE:</b> DVD devices are data only.</p>
10	Hard drives		<p>Up to six 3.5-inch hot-swappable without flex bay.</p>

## LCD Panel Features

The system's LCD panel provides system information and status messages to signify when the system is operating correctly or when the system needs attention. See "LCD Status Messages" on page 23 for information on specific status codes.

The LCD backlight lights blue during normal operating conditions and lights amber to indicate an error condition. When the system is in standby mode, the LCD backlight is off and can be turned on by pressing the **Select** button on the LCD panel. The LCD backlight will remain off if LCD messaging is turned off through the iDRAC utility, the LCD panel, or other tools.



**Figure 1-2. LCD Panel Features**



Item	Buttons	Description
1	Left	Moves the cursor back in one-step increments.
2	Select	Selects the menu item highlighted by the cursor.
3	Right	Moves the cursor forward in one-step increments.  During message scrolling: <ul style="list-style-type: none"><li>• Press once to increase scrolling speed.</li><li>• Press again to stop.</li><li>• Press again to return to default scrolling speed.</li><li>• Press again to repeat the cycle.</li></ul>
4	System ID	Turns the system ID mode on and off.  Press quickly to toggle the system ID on and off. If the system hangs during POST, press and hold the system ID button for more than five seconds to enter BIOS Progress mode.

## Home Screen

The Home screen displays user-configurable information about the system. This screen is displayed during normal system operation when there are no status messages or errors present. When the system is in standby, the LCD backlight turns off after five minutes of inactivity if there are no error messages. Press one of the three navigation buttons (Select, Left, or Right) to view the Home screen.

To navigate to the Home screen from another menu, continue to select the up arrow  until the Home icon  is displayed, and then select the Home icon.

From the Home screen, press the **Select** button to enter the main menu. See the following tables for information on the **Setup** and **View** submenus.

## Setup Menu



**NOTE:** When selecting an option in the Setup menu, you are asked to confirm the option before you can continue.

Option	Description
DRAC	Select <b>DHCP</b> or <b>Static IP</b> to configure the network mode. If <b>Static IP</b> is selected, the available fields are <b>IP</b> , <b>Subnet (Sub)</b> , and <b>Gateway (Gtw)</b> . Select <b>Setup DNS</b> to enable DNS and to view domain addresses. Two separate DNS entries are available.
Set error	Select <b>SEL</b> to display LCD error messages in a format that matches the IPMI description in the SEL log. This can be useful when trying to match an LCD message with a SEL entry.  Select <b>Simple</b> to display LCD error messages in a simplified, user-friendly description. See "LCD Status Messages" on page 23 for a list of messages in this format.
Set home	Select the default information to be displayed on the LCD Home screen. See "View Menu" on page 16 to see the options and option items that can be selected to display by default on the Home screen.

## View Menu

Option	Description
DRAC IP	Displays the <b>IPv4</b> or <b>IPv6</b> addresses for the iDRAC6. Addresses include <b>DNS (Primary and Secondary)</b> , <b>Gateway, IP</b> , and <b>Subnet</b> (IPv6 does not have Subnet).
MAC	Displays the MAC addresses for <b>DRAC</b> , <b>iSCSI<math>n</math></b> , or <b>NET<math>n</math></b> .
Name	Displays the name of the <b>Host</b> , <b>Model</b> , or <b>User String</b> for the system.



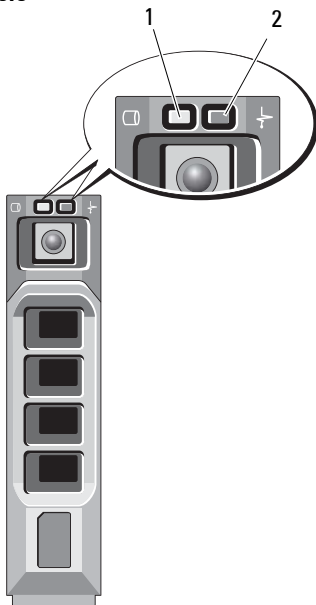
---

<b>Option</b>	<b>Description</b>
Number	Displays the <b>Asset tag</b> or the <b>Service tag</b> for the system.
Power	Displays the power output of the system in BTU/hr or Watts. The display format can be configured in the “Set home” submenu of the Setup menu (see "Setup Menu" on page 16).
Temperature	Displays the temperature of the system in Celsius or Fahrenheit. The display format can be configured in the “Set home” submenu of the Setup menu (see "Setup Menu" on page 16).

---

# Hard-Drive Indicator Patterns for RAID

Figure 1-3. Hard-Drive Indicators



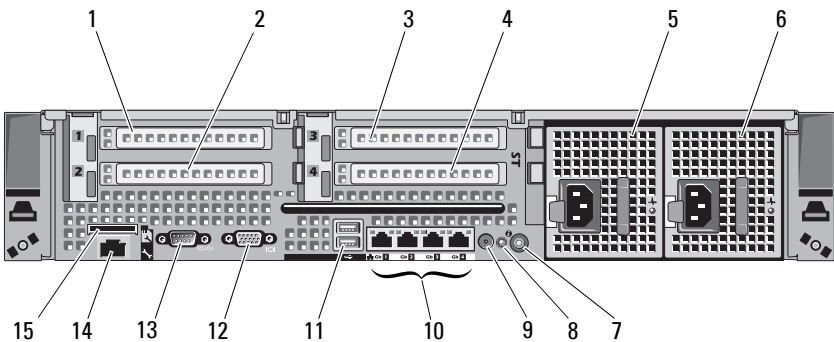
- 1 drive-activity indicator (green)
- 2 drive-status indicator (green and amber)

Drive-Status Indicator Pattern (RAID Only)	Condition
Blinks green two times per second	Identify drive/preparing for removal
Off	Drive ready for insertion or removal <b>NOTE:</b> The drive status indicator remains off until all hard drives are initialized after system power is applied. Drives are not ready for insertion or removal during this time.
Blinks green, amber, and off	Drive predicted failure








Drive-Status Indicator Pattern (RAID Only)	Condition
Blinks amber four times per second	Drive failed
Blinks green slowly	Drive rebuilding
Steady green	Drive online

## Back Panel Features and Indicators

Figure 1-4. Back Panel Features



Item	Indicator, Button, or Connector	Icon	Description
1	PCIe slot 1		PCI Express (Generation 2) x4-link expansion slot (full-height, 30.99-cm [12.2"] length)
2	PCIe slot 2		PCIe x4-link Gen 2 expansion slot (low-profile, 24.13-cm [9.5"] length)
3	PCIe slot 3		PCIe x8-link Gen 2 expansion slot (full-height, 24.13-cm [9.5"] length) or optional PCIe x16-link Gen 2 expansion slot (full-height, 24.13-cm [9.5"]) (no slot 4 with this option)

Item	Indicator, Button, or Connector	Icon	Description
4	PCIe slot 4		PCIe x8-link Gen 2 expansion slot (full-height, 24.13-cm [9.5"] length)
5	power supply 1 (PS1)		870-W or 570-W power supply
6	power supply 2 (PS2)		870-W or 570-W power supply
7	system identification button		The identification buttons on the front and back panels can be used to locate a particular system within a rack. When one of these buttons is pushed, the LCD panel on the front and the system status indicator on the back flash blue until one of the buttons is pushed again.
8	system status indicator		Provides a power on indicator for the back of the system.
9	system status indicator connector		Connector for attaching a system indicator extension cable that is used on a cable management arm.
10	Ethernet connectors (4)		Integrated 10/100/1000 NIC connectors
11	USB connectors (2)		Connects USB devices to the system. The ports are USB 2.0-complaint.
12	video connector		Connects a VGA display to the system.
13	serial connector		Connects a serial device to the system.
14	iDRAC6 Enterprise port (optional)		Dedicated management port for the optional iDRAC6 Enterprise card.
15	VFlash media slot (optional)		Connects an external SD memory card for the optional iDRAC6 Enterprise card.

## Power Indicator Codes

An LED indicator on the power button indicates when power is supplied to the system and the system is operational.

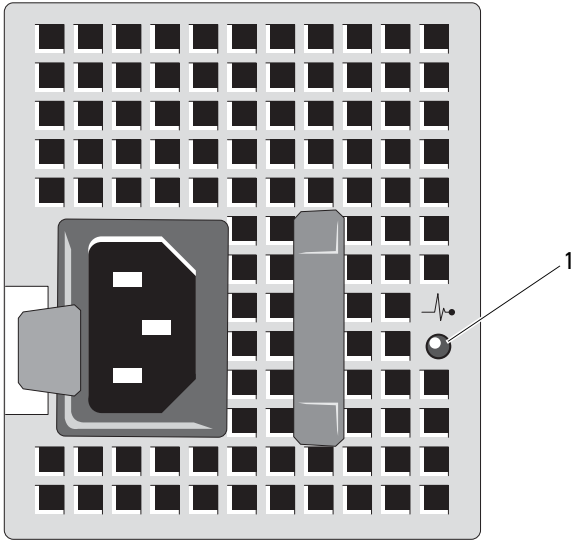
Redundant power supplies have an indicator that shows whether power is present or whether a power fault has occurred.

- Not lit—AC power is not connected.
- Green—In standby mode, indicates that a valid AC source is connected to the power supply and that the power supply is operational. When the system is on, also indicates that the power supply is providing DC power to the system.
- Amber—Indicates a problem with the power supply.
- Alternating green and amber—When hot-adding a power supply, indicates that the power supply is mismatched with the other power supply (a High Output 870-W power supply and an Energy Smart 570-W power supply are installed in the same system). Replace the power supply that has the flashing indicator with a power supply that matches the capacity of the other installed power supply.



**CAUTION:** When correcting a power supply mismatch, replace *only* the power supply with the flashing indicator. Swapping the opposite power supply to make a matched pair can result in an error condition and unexpected system shutdown. To change from a High Output configuration to an Energy Smart configuration or vice versa, you must power down the system.

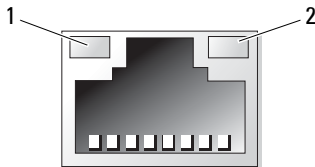
**Figure 1-5. Power Supply Status Indicator**



1 power supply status

## NIC Indicator Codes

**Figure 1-6. NIC Indicators**



1 link indicator

2 activity indicator

Indicator	Description
Link and activity indicators are off	The NIC is not connected to the network.
Link indicator is green	The NIC is connected to a valid network link at 1000 Mbps.
Link indicator is amber	The NIC is connected to a valid network link at 10/100 Mbps.
Activity indicator is green blinking	Network data is being sent or received.

## LCD Status Messages

The LCD messages consist of brief text messages that refer to events recorded in the System Event Log (SEL). For information on the SEL and configuring system management settings, see the systems management software documentation.



**NOTE:** If your system fails to boot, press the System ID button for at least five seconds until an error code appears on the LCD. Record the code, then see "Getting Help" on page 189.

### Viewing Status Messages

If a system error occurs, the LCD screen will turn amber. Press the **Select** button to view the list of errors or status messages. Use the left and right arrow buttons to highlight an error number, and press **Select** to view the error.

### Removing LCD Status Messages

For faults associated with sensors, such as temperature, voltage, fans, and so on, the LCD message is automatically removed when that sensor returns to a normal state. For other faults, you must take action to remove the message from the display:

- Clear the SEL—You can perform this task remotely, but you will lose the event history for the system.

- Power cycle—Turn off the system and disconnect it from the electrical outlet, wait for approximately ten seconds, reconnect the power cable, and restart the system.



**NOTE:** The following LCD status messages are displayed in the Simple format. See "Setup Menu" on page 16 to select the format in which the messages are displayed.

**Table 1-1. LCD Status Messages**

<b>Code</b>	<b>Text</b>	<b>Cause</b>	<b>Corrective Actions</b>
E1000	Failsafe voltage error. Contact support.	Check the system event log for critical failure events.	Remove AC power to the system for 10 seconds and restart the system.  If the problem persists, see "Getting Help" on page 189.
E1114	Ambient Temp exceeds allowed range.	Ambient temperature has a reached a point outside of the allowed range.	See "Troubleshooting System Cooling Problems" on page 161.
E1116	Memory disabled, temp above range. Power cycle AC.	Memory has exceeded allowable temperature and has been disabled to prevent damage to the components.	Remove AC power to the system for 10 seconds and restart the system.  See "Troubleshooting System Cooling Problems" on page 161. If the problem persists, see "Getting Help" on page 189.
E1210	Motherboard battery failure. Check battery.	CMOS battery is missing or the voltage is outside of the allowable range.	See "Troubleshooting the System Battery" on page 160.



**Table 1-1. LCD Status Messages (continued)**

<b>Code</b>	<b>Text</b>	<b>Cause</b>	<b>Corrective Actions</b>
E1211	RAID Controller battery failure. Check battery.	RAID battery is either missing, bad, or unable to recharge due to thermal issues.	Reseat the RAID battery connector. See "Installing a RAID Battery" on page 116 and "Troubleshooting System Cooling Problems" on page 161.
E1216	3.3V Regulator failure. Reseat PCIe cards.	3.3V voltage regulator has failed.	Remove and reseat the PCIe expansion cards. If the problem persists, see "Troubleshooting Expansion Cards" on page 170.
E1229	CPU # VCORE Regulator failure. Reseat CPU.	Specified processor VCORE voltage regulator has failed.	Reseat the processor(s). See "Troubleshooting the Processor" on page 172. If the problem persists, see "Getting Help" on page 189.
E122A	CPU # VTT Regulator failure. Reseat CPU.	Specified processor VTT voltage regulator has failed.	Reseat the processor(s). See "Troubleshooting the Processor" on page 172. If the problem persists, see "Getting Help" on page 189.
E122C	CPU Power Fault. Power cycle AC.	A power fault was detected when powering up the processor(s).	Remove AC power to the system for 10 seconds and restart the system. If the problem persists, see "Getting Help" on page 189.
E122D	Memory Regulator # Failed. Reseat DIMMs.	One of the memory regulators has failed.	Reseat the memory modules. See "Troubleshooting System Memory" on page 163.

**Table 1-1. LCD Status Messages (continued)**

<b>Code</b>	<b>Text</b>	<b>Cause</b>	<b>Corrective Actions</b>
E122E	On-board regulator failed. Call support.	One of the on-board voltage regulators failed.	Remove AC power to the system for 10 seconds and restart the system.  If the problem persists, see "Getting Help" on page 189.
E1310	Fan ## RPM exceeding range. Check fan.	RPM of specified fan is outside of the intended operating range.	See "Troubleshooting System Cooling Problems" on page 161.
E1311	Fan module ## RPM exceeding range. Check fan.	RPM of specified fan in specified module is outside of intended operating range.	See "Troubleshooting System Cooling Problems" on page 161.
E1313	Fan redundancy lost. Check fans.	The system is no longer fan redundant. Another fan failure would put the system at risk of overheating.	Check LCD for additional scrolling messages. See "Troubleshooting a Fan" on page 162.
E1410	System Fatal Error detected.	A fatal system error has been detected.	Check LCD for additional scrolling messages. Remove AC power to the system for 10 seconds and restart the system.  If the problem persists, see "Getting Help" on page 189.
E1414	CPU # temp exceeding range. Check CPU heatsink.	Specified processor is out of acceptable temperature range.	Ensure that the processor heat sinks are properly installed. See "Troubleshooting the Processor" on page 172 and "Troubleshooting System Cooling Problems" on page 161.

**Table 1-1. LCD Status Messages (continued)**

<b>Code</b>	<b>Text</b>	<b>Cause</b>	<b>Corrective Actions</b>
E1418	CPU # not detected. Check CPU is seated properly.	Specified processor is missing or bad, and the system is in an unsupported configuration.	Ensure that the specified processor is properly installed. See "Troubleshooting the Processor" on page 172.
E141C	Unsupported CPU configuration. Check CPU or BIOS revision.	Processors are in an unsupported configuration.	Ensure that your processors match and conform to the type described in the processor technical specifications outlined in your system's <i>Getting Started Guide</i> .
E141F	CPU # protocol error. Power cycle AC.	The system BIOS has reported a processor protocol error.	Remove AC power to the system for 10 seconds and restart the system. If the problem persists, see "Getting Help" on page 189.
E1420	CPU Bus parity error. Power cycle AC.	The system BIOS has reported a processor bus parity error.	Remove AC power to the system for 10 seconds and restart the system. If the problem persists, see "Getting Help" on page 189.
E1422	CPU # machine check error. Power cycle AC.	The system BIOS has reported a machine check error.	Remove AC power to the system for 10 seconds and restart the system. If the problem persists, see "Getting Help" on page 189.
E1610	Power Supply # (### W) missing. Check power supply.	Specified power supply was removed or is missing from the system.	See "Troubleshooting Power Supplies" on page 161.

**Table 1-1. LCD Status Messages (continued)**

<b>Code</b>	<b>Text</b>	<b>Cause</b>	<b>Corrective Actions</b>
E1614	Power Supply # (### W) error. Check power supply.	Specified power supply has failed.	See "Troubleshooting Power Supplies" on page 161.
E1618	Predictive failure on Power Supply # (### W). Check PSU.	A power supply fan failure, an over-temperature condition, or power supply communication error has caused the predictive warning of an impending power supply failure.	See "Troubleshooting Power Supplies" on page 161.
E161C	Power Supply # (### W) lost AC power. Check PSU cables.	Specified power supply is attached to the system, but it has lost its AC input.	Check the AC power source for the specified power supply. If the problem persists, see "Troubleshooting Power Supplies" on page 161.
E1620	Power Supply # (### W) AC power error. Check PSU cables.	Specified power supply's AC input is outside of the allowable range.	Check the AC power source for the specified power supply. If the problem persists, see "Troubleshooting Power Supplies" on page 161.
E1624	Lost power supply redundancy. Check PSU cables.	The power supply subsystem is no longer redundant. If the remaining power supply fails, the system will shut down.	See "Troubleshooting Power Supplies" on page 161.
E1626	Power Supply Mismatch. PSU1 = ### W, PSU2 = ### W.	The power supplies in the system are not the same wattage.	Ensure that power supplies with matching wattage are installed. See the Technical Specifications outlined in your system's <i>Getting Started Guide</i> .

**Table 1-1. LCD Status Messages (continued)**

<b>Code</b>	<b>Text</b>	<b>Cause</b>	<b>Corrective Actions</b>
E1629	Power required > PSU wattage. Check PSU and config.	The system configuration requires more power than the power supplies can provide, even with throttling.	Turn off power to the system, reduce the hardware configuration or install higher-wattage power supplies, and then restart the system.
E1710	I/O channel check error. Review & clear SEL.	The system BIOS has reported an I/O channel check.	Check the SEL for more information and then clear the SEL. Remove AC power to the system for 10 seconds and restart the system.  If the problem persists, see "Getting Help" on page 189.
E1711	PCI parity error on Bus ## Device ## Function ##	The system BIOS has reported a PCI parity error on a component that resides in PCI configuration space at bus ##, device ##, function ##.	Remove and reseal the PCIe expansion cards. If the problem persists, see "Troubleshooting Expansion Cards" on page 170.
	PCI parity error on Slot #. Review & clear SEL.	The system BIOS has reported a PCI parity error on a component that resides in the specified slot.	Remove and reseal the PCIe expansion cards. If the problem persists, see "Troubleshooting Expansion Cards" on page 170.

**Table 1-1. LCD Status Messages (continued)**

<b>Code</b>	<b>Text</b>	<b>Cause</b>	<b>Corrective Actions</b>
E1712	PCI system error on Bus ## Device ## Function ##	The system BIOS has reported a PCI system error on a component that resides in PCI configuration space at bus ##, device ##, function ##.	Remove and reseal the PCIe expansion cards. If the problem persists, see "Troubleshooting Expansion Cards" on page 170.
	PCI system error on Slot #. Review & clear SEL.	The system BIOS has reported a PCI system error on a component that resides in the specified slot.	Reinstall the expansion-card riser. See "Expansion Cards and Expansion-Card Risers" on page 120. If the problem persists, the riser card or system board is faulty. See "Getting Help" on page 189.
E1714	Unknown error. Review & clear SEL.	The system BIOS has determined there has been an error in the system, but is unable to determine its origin.	Check the SEL for more information and then clear the SEL. Remove AC power to the system for 10 seconds and restart the system. If the problem persists, see "Getting Help" on page 189.
E1715	Fatal I/O Error. Review & clear SEL.	The system BIOS has determined there has been a fatal error in the system.	Check the SEL for more information, and then clear the SEL. Remove AC power to the system for 10 seconds, and restart the system. If the problem persists, see "Getting Help" on page 189.

**Table 1-1. LCD Status Messages (continued)**

<b>Code</b>	<b>Text</b>	<b>Cause</b>	<b>Corrective Actions</b>
E1716	Chipset IERR Bus ## Dev ## Function ##. Review & clear SEL.	The system BIOS has reported a chipset internal error that resides in bus ##, device ##, function ##.	Check the SEL for more information, and then clear the SEL. Remove AC power to the system for 10 seconds, and restart the system.  If the problem persists, see "Getting Help" on page 189.
E1717	CPU # internal error. Review & clear SEL.	The system BIOS has determined that the specified processor has had an internal error.	Check the SEL for more information, and then clear the SEL. Remove AC power to the system for 10 seconds, and restart the system.  If the problem persists, see "Getting Help" on page 189.
E171F	PCIe fatal error on Bus ## Device ## Function ##	The system BIOS has reported a PCIe fatal error on a component that resides in PCI configuration space at bus ##, device ##, function ##.	Remove and reseat the PCIe expansion cards. If the problem persists, see "Troubleshooting Expansion Cards" on page 170.
	PCIe fatal error on Slot #. Review & clear SEL.	The system BIOS has reported a PCIe fatal error on a component that resides in the specified slot.	Reinstall the expansion-card riser. See "Expansion Cards and Expansion-Card Risers" on page 120. If the problem persists, the riser card or system board is faulty. See "Getting Help" on page 189.

**Table 1-1. LCD Status Messages (continued)**

<b>Code</b>	<b>Text</b>	<b>Cause</b>	<b>Corrective Actions</b>
E1810	Hard drive ## fault. Review & clear SEL.	The specified hard drive has experienced a fault.	See "Troubleshooting a Hard Drive" on page 168.
E1812	Hard drive ## removed. Check drive.	The specified hard drive has been removed from the system.	Information only.
E1A11	PCI Riser hardware & configuration mismatch. Reconfigure.	PCIe risers are not configured correctly. Some invalid configurations prevent the system from powering on.	Reinstall the expansion-card riser. See "Expansion Cards and Expansion-Card Risers" on page 120.  If the problem persists, the riser card or system board is faulty. See "Getting Help" on page 189.
E1A12	PCI Riser not detected. Check Riser.	One or both of the PCIe risers are missing. This prevents the system from powering on.	Reinstall the missing riser card(s). See "Replacing Expansion-Card Riser 1" on page 125 and "Replacing Expansion-Card Riser 2" on page 127.
E1A14	SAS cable A failure. Check connection.	SAS cable A is missing or bad.	Reseat the cable. If the problem persists, replace cable.  If the problem persists, see "Getting Help" on page 189.
E1A15	SAS cable B failure. Check connection.	SAS cable B is missing or bad.	Reseat the cable. If the problem persists, replace cable.  If the problem persists, see "Getting Help" on page 189.



**Table 1-1. LCD Status Messages (continued)**

<b>Code</b>	<b>Text</b>	<b>Cause</b>	<b>Corrective Actions</b>
E1A1D	Control panel USB cable not detected. Check cable.	USB cable to the control panel is missing or bad.	Reseat the cable. If the problem persists, replace cable.  If the problem persists, see "Getting Help" on page 189.
E2010	Memory not detected. Inspect DIMMs.	No memory was detected in the system.	Install memory or reseat the memory modules. See "Installing Memory Modules" on page 135 or "Troubleshooting System Memory" on page 163.
E2011	Memory configuration failure. Check DIMMs.	Memory detected, but is not configurable. Error detected during memory configuration.	See "Troubleshooting System Memory" on page 163.
E2012	Memory configured but unusable. Check DIMMs.	Memory configured, but is unusable.	See "Troubleshooting System Memory" on page 163.
E2013	BIOS unable to shadow memory. Check DIMMs.	The system BIOS failed to copy its flash image into memory.	See "Troubleshooting System Memory" on page 163.
E2014	CMOS RAM failure. Power cycle AC.	CMOS failure. CMOS RAM not functioning properly.	Remove AC power to the system for 10 seconds and restart the system.  If the problem persists, see "Getting Help" on page 189.

**Table 1-1. LCD Status Messages (continued)**

<b>Code</b>	<b>Text</b>	<b>Cause</b>	<b>Corrective Actions</b>
E2015	DMA Controller failure. Power cycle AC.	DMA controller failure.	Remove AC power to the system for 10 seconds and restart the system.  If the problem persists, see "Getting Help" on page 189.
E2016	Interrupt Controller failure. Power cycle AC.	Interrupt controller failure.	Remove AC power to the system for 10 seconds and restart the system.  If the problem persists, see "Getting Help" on page 189.
E2017	Timer refresh failure. Power cycle AC.	Timer refresh failure.	Remove AC power to the system for 10 seconds and restart the system.  If the problem persists, see "Getting Help" on page 189.
E2018	Programmable Timer error. Power cycle AC.	Programmable interval timer error.	Remove AC power to the system for 10 seconds and restart the system.  If the problem persists, see "Getting Help" on page 189.
E2019	Parity error. Power cycle AC.	Parity error.	Remove AC power to the system for 10 seconds and restart the system.  If the problem persists, see "Getting Help" on page 189.

**Table 1-1. LCD Status Messages (continued)**

<b>Code</b>	<b>Text</b>	<b>Cause</b>	<b>Corrective Actions</b>
E201A	SuperIO failure. Power cycle AC.	SIO failure.	Remove AC power to the system for 10 seconds and restart the system.  If the problem persists, see "Getting Help" on page 189.
E201B	Keyboard Controller error. Power cycle AC.	Keyboard controller failure.	Remove AC power to the system for 10 seconds and restart the system.  If the problem persists, see "Getting Help" on page 189.
E201C	SMI initialization failure. Power cycle AC.	System management interrupt (SMI) initialization failure.	Remove AC power to the system for 10 seconds and restart the system.  If the problem persists, see "Getting Help" on page 189.
E201D	Shutdown test failure. Power cycle AC.	BIOS shutdown test failure.	Remove AC power to the system for 10 seconds and restart the system.  If the problem persists, see "Getting Help" on page 189.
E201E	POST memory test failure. Check DIMMs.	BIOS POST memory test failure.	See "Troubleshooting System Memory" on page 163.  If the problem persists, see "Getting Help" on page 189.
E2020	CPU configuration failure. Check screen message.	Processor configuration failure.	Check screen for specific error messages. See "Troubleshooting the Processor" on page 172.

**Table 1-1. LCD Status Messages (continued)**

<b>Code</b>	<b>Text</b>	<b>Cause</b>	<b>Corrective Actions</b>
E2021	Incorrect memory configuration. Review User Guide.	Incorrect memory configuration.	Check screen for specific error messages. See "Troubleshooting System Memory" on page 163.
E2022	General failure during POST. Check screen message.	General failure after video.	Check screen for specific error messages.
E2023	BIOS unable to mirror memory. Check DIMMs.	The system BIOS could not enable memory mirroring because of a faulty memory module or an invalid memory configuration.	See "Troubleshooting System Memory" on page 163.
E2110	Multibit Error on DIMM ##. Reseat DIMM.	The memory module in slot "##" has had a multi-bit error (MBE).	See "Troubleshooting System Memory" on page 163.
E2111	SBE log disabled on DIMM ##. Reseat DIMM.	The system BIOS has disabled memory single-bit error (SBE) logging and will not log any more SBEs until the system is rebooted. "##" represents the memory module implicated by the BIOS.	Remove AC power to the system for 10 seconds and restart the system. If the problem persists, see "Troubleshooting System Memory" on page 163.
E2113	Mem mirror OFF on DIMM ## & ##. Power cycle AC.	The system BIOS has disabled memory mirroring because it has determined one half of the mirror has had too many errors. "## & ##" represents the memory module pair implicated by the BIOS.	Remove AC power to the system for 10 seconds and restart the system. If the problem persists, see "Troubleshooting System Memory" on page 163.

**Table 1-1. LCD Status Messages (continued)**

<b>Code</b>	<b>Text</b>	<b>Cause</b>	<b>Corrective Actions</b>
I1910	Intrusion detected. Check chassis cover.	System cover has been removed.	Information only.
I1911	LCD Log Full. Check SEL to review all Errors.	LCD overflow message. A maximum of ten error messages can display sequentially on the LCD. The eleventh message instructs the user to check the SEL for details on the events.	Check the SEL for details on the events.  Remove AC power to the system for 10 seconds or clear the SEL.
I1912	SEL full. Review & clear log.	The SEL is full of events and is unable to log any more.	Check the SEL for more information and then clear the SEL.
W1228	RAID Controller battery capacity < 24hr.	Warns predictively that the RAID battery has less than 24 hours of charge left.	Allow RAID battery to charge to greater than 24 hours of sustained charge.  If problem persists, replace the RAID battery. See "Installing a RAID Battery" on page 116.
W1627	Power required > PSU wattage. Check PSU and config.	The system configuration requires more power than what the power supply can provide.	Turn off power to the system, reduce the hardware configuration or install higher-wattage power supplies, and then restart the system.
W1628	Performance degraded. Check PSU and system configuration.	The system configuration requires more power than what the power supply can provide, but it can boot if throttled.	Turn off power to the system, reduce the hardware configuration or install higher-wattage power supplies, and then restart the system.

**NOTE:** For the full name of an abbreviation or acronym used in this table, see the *Glossary* on [support.dell.com/manuals](http://support.dell.com/manuals).

# System Messages

System messages appear on the screen to notify you of a possible problem with the system.



**NOTE:** If you receive a system message not listed in the table, check the documentation for the application that is running when the message appears or the operating system's documentation for an explanation of the message and recommended action.

**Table 1-2. System Messages**

Message	Causes	Corrective Actions
128-bit Advanced ECC mode disabled. For 128-bit Advanced ECC, DIMMs must be installed in pairs. Pairs must be matched in size and geometry.	The Advanced ECC option was enabled in BIOS, but is no longer valid due to an unsupported memory configuration, possibly a faulty or removed memory module. The Advanced ECC setting has been disabled.	Check other messages for a faulty memory module. Reconfigure the memory modules for Advanced ECC mode. See "System Memory" on page 130.
Alert! Advanced ECC Memory Mode disabled! Memory configuration does not support Advanced ECC Memory Mode.	Advanced ECC Memory Mode was enabled in the system setup program, but the current configuration does not support Advanced ECC Memory Mode. A memory module may be faulty.	Ensure that the memory modules are installed in a configuration that supports Advanced ECC Memory Mode. Check other system messages for additional information for possible causes. For memory configuration information, see "General Memory Module Installation Guidelines" on page 131. If the problem persists, see "Troubleshooting System Memory" on page 163.

**Table 1-2. System Messages (continued)**

<b>Message</b>	<b>Causes</b>	<b>Corrective Actions</b>
Alert! iDRAC6 not responding. Rebooting.	The iDRAC6 is not responding to BIOS communication either because it is not functioning properly or has not completed initialization. The system will reboot.	Wait for the system to reboot.
Alert! iDRAC6 not responding. Power required may exceed PSU wattage. Alert! Continuing system boot accepts the risk that system may power down without warning.	The iDRAC6 is hung. The iDRAC6 was remotely reset while system was booting After AC recovery, the iDRAC6 takes longer than normal to boot.	Remove AC power to the system for 10 seconds and restart the system.
Alert! Node Interleaving disabled! Memory configuration does not support Node Interleaving.	The memory configuration does not support node interleaving, or the configuration has changed (for example, a memory module has failed) so that node interleaving cannot be supported. The system will run but without node interleaving.	Ensure that the memory modules are installed in a configuration that supports node interleaving. Check other system messages for additional information for possible causes. For memory configuration information, see "General Memory Module Installation Guidelines" on page 131. If the problem persists, see "Troubleshooting System Memory" on page 163.

**Table 1-2. System Messages (continued)**

<b>Message</b>	<b>Causes</b>	<b>Corrective Actions</b>
Alert! Power required exceeds PSU wattage. Check PSU and system configuration.	The system configuration of processor(s), memory modules, and expansion cards may not be supported by the power supplies.	If any system components were just upgraded, return the system to the previous configuration. If the system boots without this warning, then the replaced component(s) are not supported with this power supply. If Energy Smart power supplies are installed, replace them with the High Output power supplies to use the components. See "Power Supplies" on page 90.
Alert! Continuing system boot accepts the risk that system may power down without warning.		
Alert! Redundant memory disabled! Memory configuration does not support redundant memory.	Memory Mirroring was enabled in the system setup program, but the current configuration does not support redundant memory. A memory module may be faulty.	Check the memory modules for failure. See "Troubleshooting System Memory" on page 163. Reset the memory setting, if appropriate. See "Using the System Setup Program and UEFI Boot Manager" on page 57.
Alert! System fatal error during previous boot.	An error caused the system to reboot.	Check other system messages for additional information for possible causes.



**Table 1-2. System Messages (continued)**

<b>Message</b>	<b>Causes</b>	<b>Corrective Actions</b>
BIOS MANUFACTURING MODE detected. MANUFACTURING MODE will be cleared before the next boot. System reboot required for normal operation.	System is in manufacturing mode.	Reboot to take the system out of manufacturing mode.
BIOS Update Attempt Failed!	Remote BIOS update attempt failed.	Retry the BIOS update. If problem persists, see "Getting Help" on page 189.
Caution! NVRAM_CLR jumper is installed on system board.	NVRAM_CLR jumper is installed in the clear setting. CMOS has been cleared.	Move the NVRAM_CLR jumper to the default position (pins 3 and 5). See Figure 6-1 for jumper location. Restart the system and re-enter the BIOS settings. See "Using the System Setup Program and UEFI Boot Manager" on page 57.
CPU set to minimum frequency.	The processor speed may be intentionally set lower for power conservation.	If not an intentional setting, check any other system messages for possible causes.
CPU x installed with no memory.	Memory modules are required but not installed in the indicated processor's memory slots.	Install memory modules for the processor. See "System Memory" on page 130.

**Table 1-2. System Messages (continued)**

<b>Message</b>	<b>Causes</b>	<b>Corrective Actions</b>
CPUs with different cache sizes detected.	Mismatched processors have been installed in the system.	Ensure that all processors have the same cache size, number of cores and logical processors, and power rating.
CPUs with different core sizes detected! System halted.		Ensure that the processors are properly installed. See "Processors" on page 138.
CPUs with different logical processors detected! System halted.		
CPUs with different power rating detected! System halted.		
Current boot mode is set to UEFI. Please ensure compatible bootable media is available. Use the system setup program to change the boot mode as needed.	The system failed to boot because UEFI boot mode is enabled in BIOS and the boot operating system is non-UEFI.	Ensure that the boot mode is set correctly and that the proper bootable media is available. See "Using the System Setup Program and UEFI Boot Manager" on page 57.
Decreasing available memory.	Faulty or improperly installed memory modules.	Reseat the memory modules. See "Troubleshooting System Memory" on page 163.
DIMM configuration on each CPU should match.	Invalid memory configuration on a dual-processor system. The memory module configuration for each processor must be identical.	Ensure that the memory modules are installed in a valid configuration. See "General Memory Module Installation Guidelines" on page 131.

**Table 1-2. System Messages (continued)**

<b>Message</b>	<b>Causes</b>	<b>Corrective Actions</b>
Embedded NICx and NICy: OS NIC=<ENABLED /DISABLED>, Management Shared NIC= <ENABLED /DISABLED>	The OS NIC interface is set in BIOS. The Management Shared NIC interface is set in management tools.	Check the system management software or the System Setup program for NIC settings. If a problem is indicated, see "Troubleshooting a NIC" on page 157.
Error 8602 - Auxiliary Device Failure. Verify that mouse and keyboard are securely attached to correct connectors.	Mouse or keyboard cable is loose or improperly connected.  Defective mouse or keyboard.	Reseat the mouse or keyboard cable.  Ensure that the mouse or keyboard is operational. See "Troubleshooting a USB Device" on page 156.
Gate A20 failure.	Faulty keyboard controller; faulty system board.	See "Getting Help" on page 189.
General failure.	The operating system is unable to carry out the command.	This message is usually followed by specific information. Note the information, and take the appropriate action to resolve the problem.
Invalid configuration information - please run SETUP program.	An invalid system configuration caused a system halt.	Run the System Setup program and review the current settings. See "Using the System Setup Program and UEFI Boot Manager" on page 57.

**Table 1-2. System Messages (continued)**

<b>Message</b>	<b>Causes</b>	<b>Corrective Actions</b>
Invalid PCIe card found in the Internal_Storage slot!	The system halted because an invalid PCIe expansion card is installed in the dedicated storage controller slot.	Remove the PCIe expansion card and install the integrated storage controller in the dedicated slot. See "Integrated Storage Controller Card" on page 112.
Keyboard controller failure.	Faulty keyboard controller; faulty system board	See "Getting Help" on page 189.
Keyboard data line failure. Keyboard stuck key failure.	Keyboard cable connector is improperly connected or the keyboard is defective.	Reseat the keyboard cable. If the problem persists, see "Troubleshooting a USB Device" on page 156.
Keyboard fuse has failed.	Overcurrent detected at the keyboard connector.	See "Getting Help" on page 189.
Local keyboard may not work because all user accessible USB ports are disabled. If operating locally, power cycle the system and enter system setup program to change settings.	The USB ports are disabled in the system BIOS.	Power down and restart the system from the power button, and then enter the System Setup program to enable the USB port(s). See "Entering the System Setup Program" on page 58.
Manufacturing mode detected.	System is in manufacturing mode.	Reboot to take the system out of manufacturing mode.
Maximum rank count exceeded. The following DIMM has been disabled: x	Invalid memory configuration. The system will run but with the specified memory module disabled.	Ensure that the memory modules are installed in a valid configuration. See "General Memory Module Installation Guidelines" on page 131.

**Table 1-2. System Messages (continued)**

<b>Message</b>	<b>Causes</b>	<b>Corrective Actions</b>
Memory address line failure at <i>address</i> , read value expecting <i>value</i> .	Faulty or improperly installed memory modules.	See "Troubleshooting System Memory" on page 163.
Memory double word logic failure at <i>address</i> , read value expecting <i>value</i>	Faulty or improperly installed memory modules.	See "Troubleshooting System Memory" on page 163.
Memory Initialization Warning: Memory size may be reduced.	Invalid memory configuration. The system will run but with less memory than is physically available.	Ensure that the memory modules are installed in a valid configuration. See "General Memory Module Installation Guidelines" on page 131.
Memory odd/even logic failure at <i>address</i> , read value expecting <i>value</i> .	Faulty or improperly installed memory modules.	See "Troubleshooting System Memory" on page 163.
Memory write/read failure at <i>address</i> , read value expecting <i>value</i> .	Faulty or improperly installed memory modules.	See "Troubleshooting System Memory" on page 163.

**Table 1-2. System Messages (continued)**

<b>Message</b>	<b>Causes</b>	<b>Corrective Actions</b>
Memory set to minimum frequency.	<p>The memory frequency may be intentionally set lower for power conservation.</p> <p>The current memory configuration may support only the minimum frequency.</p>	<p>If not an intentional setting, check any other system messages for possible causes.</p> <p>Ensure that your memory configuration supports the higher frequency. See "General Memory Module Installation Guidelines" on page 131.</p>
Memory tests terminated by keystroke.	POST memory test was terminated by pressing the spacebar.	Information only.
MEMTEST lane failure detected on x.	Invalid memory configuration. A mismatched memory module is installed.	Ensure that the memory modules are installed in a valid configuration. See "General Memory Module Installation Guidelines" on page 131.
Mirror mode disabled. For mirror mode, DIMMs must be installed in pairs. Pairs must be matched in size and geometry.	The memory configuration does not match the setting in BIOS. The BIOS setting has been disabled.	Reconfigure the memory modules for Memory Mirroring mode. See "System Memory" on page 130.

**Table 1-2. System Messages (continued)**

<b>Message</b>	<b>Causes</b>	<b>Corrective Actions</b>
No boot device available.	Faulty or missing optical drive subsystem, hard drive, or hard-drive subsystem, or no bootable USB key installed.	Use a bootable USB key, CD, or hard drive. If the problem persists, see "Troubleshooting an Internal SD Card" on page 165, "Troubleshooting a USB Device" on page 156, "Troubleshooting an Optical Drive" on page 167, and "Troubleshooting a Hard Drive" on page 168. See "Using the System Setup Program and UEFI Boot Manager" on page 57 for information on setting the order of boot devices.
No boot sector on hard drive.	Incorrect configuration settings in System Setup program, or no operating system on hard drive.	Check the hard-drive configuration settings in the System Setup program. See "Using the System Setup Program and UEFI Boot Manager" on page 57. If necessary, install the operating system on your hard drive. See your operating system documentation.
No timer tick interrupt.	Faulty system board.	See "Getting Help" on page 189.
PCI BIOS failed to install.	PCIe device BIOS (Option ROM) checksum failure detected during shadowing. Cables to expansion card(s) loose; faulty or improperly installed expansion card(s).	Reseat the expansion card(s). Ensure that all appropriate cables are securely connected to the expansion card(s). If the problem persists, see "Troubleshooting Expansion Cards" on page 170.

**Table 1-2. System Messages (continued)**

<b>Message</b>	<b>Causes</b>	<b>Corrective Actions</b>
PCIe Training Error: Expected Link Width is x, Actual Link Width is y.	Faulty or improperly installed PCIe card in the specified slot.	Reseat the PCIe card in the specified slot number. See "Troubleshooting Expansion Cards" on page 170. If the problem persists, see "Getting Help" on page 189.
Plug & Play Configuration Error.	Error encountered in initializing PCIe device; faulty system board.	Install the NVRAM_CLR jumper in the clear position (pins 1 and 3) and reboot the system. See Figure 6-1 for jumper location. If the problem persists, see "Troubleshooting Expansion Cards" on page 170.
Quad rank DIMM detected after single rank or dual rank DIMM in socket.	Invalid memory configuration.	Ensure that the memory modules are installed in a valid configuration. See "General Memory Module Installation Guidelines" on page 131.
Read fault. Requested sector not found.	The operating system cannot read from the hard drive, optical drive, or USB device, the system could not find a particular sector on the disk, or the requested sector is defective.	Replace the optical medium, USB medium or device. Ensure that the SAS backplane, USB, or SATA cables are properly connected. See "Troubleshooting a USB Device" on page 156, "Troubleshooting an Optical Drive" on page 167, or "Troubleshooting a Hard Drive" on page 168 for the appropriate drive(s) installed in your system.
SATA Portx device not found.	There is no device connected to the specified SATA port.	Information only.



**Table 1-2. System Messages (continued)**

<b>Message</b>	<b>Causes</b>	<b>Corrective Actions</b>
SATA port x device auto-sensing error.	The drive connected to the specified SATA port is faulty.	Replace the faulty drive.
SATA port x device configuration error.		
SATA port x device error.		
Sector not found. Seek error. Seek operation failed.	Faulty hard drive, USB device, or USB medium.	Replace the USB medium or device. Ensure that the USB or SAS backplane cables are properly connected. See "Troubleshooting a USB Device" on page 156 or "Troubleshooting a Hard Drive" on page 168 for the appropriate drive(s) installed in your system.
Shutdown failure.	General system error.	See "Getting Help" on page 189.
The amount of system memory has changed.	Memory has been added or removed or a memory module may be faulty.	If memory has been added or removed, this message is informative and can be ignored. If memory has not been added or removed, check the SEL to determine if single-bit or multi-bit errors were detected and replace the faulty memory module. See "Troubleshooting System Memory" on page 163.

**Table 1-2. System Messages (continued)**

<b>Message</b>	<b>Causes</b>	<b>Corrective Actions</b>
<p>The following DIMMs should match in geometry: x,x,...</p> <p>The following DIMMs should match in rank count: x,x,...</p> <p>The following DIMMs should match in size: x,x,...</p> <p>The following DIMMs should match in size and geometry: x,x,...</p> <p>The following DIMMs should match in size and rank count: x,x,...</p>	<p>Invalid memory configuration. The specified memory modules do not match in size, number of ranks, or number of data lanes.</p>	<p>Ensure that the memory modules are installed in a valid configuration. See "General Memory Module Installation Guidelines" on page 131.</p>
<p>Thermal sensor not detected on x.</p>	<p>A memory module without a thermal sensor is installed in the specified memory slot</p>	<p>Replace the memory module. See "System Memory" on page 130.</p>
<p>Time-of-day clock stopped.</p>	<p>Faulty battery or faulty chip.</p>	<p>See "Troubleshooting the System Battery" on page 160.</p>
<p>Time-of-day not set - please run SETUP program.</p>	<p>Incorrect Time or Date settings; faulty system battery.</p>	<p>Check the Time and Date settings. See "Using the System Setup Program and UEFI Boot Manager" on page 57. If the problem persists, replace the system battery. See "System Battery" on page 143.</p>

**Table 1-2. System Messages (continued)**

<b>Message</b>	<b>Causes</b>	<b>Corrective Actions</b>
Timer chip counter 2 failed.	Faulty system board.	See "Getting Help" on page 189.
TPM configuration operation honored. System will now reset.	A TPM configuration command has been entered. The system will reboot and execute the command.	Information only.
TPM configuration operation is pending. Press (I) to Ignore OR (M) to Modify to allow this change and reset the system.  WARNING: Modifying could prevent security.	This message displays during system restart after a TPM configuration command has been entered. User interaction is required to proceed.	Enter I or M to proceed.
TPM failure.	A Trusted Platform Module (TPM) function has failed.	See "Getting Help" on page 189.

**Table 1-2. System Messages (continued)**

<b>Message</b>	<b>Causes</b>	<b>Corrective Actions</b>
Unable to launch System Services image. System halted!	System halted after <F10> keystroke because System Services image is either corrupted in the system firmware or has been lost due to system board replacement.  The iDRAC6 Enterprise card flash memory may be corrupted.	Restart the system and update the Unified Server Configurator repository to the latest software to restore full functionality. See the Unified Server Configuration user documentation for more information.  Restore the flash memory using the latest version on support.dell.com. See the iDRAC6 user's guide for instructions on performing a field replacement of the flash memory.
Unexpected interrupt in protected mode.	Improperly seated memory modules or faulty keyboard/mouse controller chip.	Reseat the memory modules. See "Troubleshooting System Memory" on page 163. If the problem persists, see "Getting Help" on page 189.
Unsupported CPU combination.  Unsupported CPU stepping detected.	Processor(s) is not supported by the system.	Install a supported processor or processor combination. See "Processors" on page 138.
Unsupported DIMM detected. The following DIMM has been disabled: x	Invalid memory configuration. The system will run but with the specified memory module disabled.	Ensure that the memory modules are installed in a valid configuration. See "General Memory Module Installation Guidelines" on page 131.

**Table 1-2. System Messages (continued)**

<b>Message</b>	<b>Causes</b>	<b>Corrective Actions</b>
Unsupported memory configuration. DIMM mismatch across slots detected: <i>x,x,...</i>	Invalid memory configuration. Memory modules are mismatched in the specified slots.	Ensure that the memory modules are installed in a valid configuration. See "General Memory Module Installation Guidelines" on page 131.
Unused memory detected. DIMM's installed in the following slot are not available when in mirror or 128-bit advanced ECC modes: <i>x,x,x</i>	The memory configuration is not optimal for mirroring or Advanced ECC Memory Mode. Modules in the specified slots are unused.	Reconfigure the memory for Memory Mirroring or Advanced ECC Memory Mode, or change the memory mode to <b>Optimized</b> in the BIOS setup screen. See "System Memory" on page 130.
Warning: A fatal error has caused system reset! Please check the system event log!	A fatal system error occurred and caused the system to reboot.	Check the SEL for information that was logged during the error. See the applicable troubleshooting section in "Troubleshooting Your System" on page 155 for any faulty components specified in the SEL.
Warning: Control Panel is not installed.	The control panel is not installed or has a faulty cable connection.	Install the control panel, or check the cable connections between the display module, the control panel board, and the system board. See "Control Panel Assembly" on page 145.
Warning! No micro code update loaded for processor <i>n</i> .	Micro code update failed.	Update the BIOS firmware. See "Getting Help" on page 189.

**Table 1-2. System Messages (continued)**

<b>Message</b>	<b>Causes</b>	<b>Corrective Actions</b>
Warning! Power required exceeds PSU wattage. Check PSU and system configuration.	The system configuration of processor(s), memory modules, and expansion cards may not be supported by the power supplies.	If any system components were just upgraded, return the system to the previous configuration. If the system boots without this warning, then the replaced component(s) are not supported with this power supply. If Energy Smart power supplies are installed, replace them with High Output power supplies to use the components. See "Power Supplies" on page 90.
Warning! Performance degraded. CPU and memory set to minimum frequencies to meet PSU wattage. System will reboot.		
Warning! PSU mismatch. PSU redundancy lost. Check PSU.	A High Output power supply and an Energy Smart power supply are installed in the system at the same time.	Install two High Output or two Energy Smart power supplies in the system. You can also run the system on one power supply until you can obtain two power supplies of the same type. See "Troubleshooting Power Supplies" on page 161.
Warning! Unsupported memory configuration detected. The memory configuration is not optimal. The recommended memory configuration is: <message>.	Invalid memory configuration. The system will run but with reduced functionality.	Ensure that the memory modules are installed in a valid configuration. See "General Memory Module Installation Guidelines" on page 131. If the problem persists, see "Troubleshooting System Memory" on page 163.


**Table 1-2. System Messages (continued)**

<b>Message</b>	<b>Causes</b>	<b>Corrective Actions</b>
Write fault. Write fault on selected drive.	Faulty USB device, USB medium, optical drive assembly, hard drive, or hard-drive subsystem.	Replace the USB medium or device. Ensure that the USB, SAS backplane, or SATA cables are properly connected. See "Troubleshooting a USB Device" on page 156, "Troubleshooting an Internal SD Card" on page 165, and "Troubleshooting a Hard Drive" on page 168.

**NOTE:** For the full name of an abbreviation or acronym used in this table, see the *Glossary* on [support.dell.com/manuals](http://support.dell.com/manuals).

## Warning Messages

A warning message alerts you to a possible problem and prompts you to respond before the system continues a task. For example, before you format a drive, a message will warn you that you may lose all data on the drive. Warning messages usually interrupt the task and require you to respond by typing *y* (yes) or *n* (no).

 **NOTE:** Warning messages are generated by either the application or the operating system. For more information, see the documentation that accompanied the operating system or application.

## Diagnostics Messages

The system diagnostic utilities may issue messages if you run diagnostic tests on your system. See "Running the System Diagnostics" on page 173 for more information about system diagnostics.

## Alert Messages

Systems management software generates alert messages for your system. Alert messages include information, status, warning, and failure messages for drive, temperature, fan, and power conditions. For more information, see the systems management software documentation.

## Other Information You May Need



**WARNING:** See the safety and regulatory information that shipped with your system. Warranty information may be included within that document or as a separate document.

- The rack documentation included with your rack solution describes how to install your system into a rack.
- The *Getting Started Guide* provides an overview of system features, setting up your system, and technical specifications.
- Any media that ships with your system that provides documentation and tools for configuring and managing your system, including those pertaining to the operating system, system management software, system updates, and system components that you purchased with your system.



**NOTE:** Always check for updates on [support.dell.com](https://support.dell.com) and read the updates first because they often supersede information in other documents.



# Using the System Setup Program and UEFI Boot Manager

The System Setup program is the BIOS program that enables you to manage your system hardware and specify BIOS-level options. From the System Setup program, you can:

- Change the NVRAM settings after you add or remove hardware
- View the system hardware configuration
- Enable or disable integrated devices
- Set performance and power management thresholds
- Manage system security

## Choosing the System Boot Mode

The System Setup program also enables you to specify the boot mode for installing your operating system:

- BIOS boot mode (the default) is the standard BIOS-level boot interface.
- UEFI boot mode is an enhanced 64-bit boot interface based on Unified Extensible Firmware Interface (UEFI) specifications that overlays the system BIOS. See "Entering the UEFI Boot Manager" on page 70 for more information on this interface.

You select the boot mode in the **Boot Mode** field of the Boot Settings screen of the System Setup program. See "Boot Settings Screen" on page 63. Once you specify the boot mode, the system boots in the specified boot mode and you install your operating system from that mode. Thereafter, you must boot the system to the same boot mode (BIOS or UEFI) to access the installed operating system. Trying to boot the operating system from the other boot mode will cause the system to halt immediately at startup.



**NOTE:** Operating systems must be UEFI-compatible (for example, Microsoft® Windows Server® 2008 x64 version) to be installed from the UEFI boot mode. DOS and 32-bit operating systems do not support UEFI and can only be installed from the BIOS boot mode.

## Entering the System Setup Program

- 1 Turn on or restart your system.
- 2 Press <F2> after you see the following message:

<F2> = System Setup



**NOTE:** The system will not respond until the USB keyboard is active.

If your operating system begins to load before you press <F2>, allow the system to finish booting, and then restart your system and try again.

## Responding to Error Messages

If an error message appears while the system is booting, make a note of the message. See "System Messages" on page 38 for an explanation of the message and suggestions for correcting errors.



**NOTE:** After installing a memory upgrade, it is normal for your system to display a message that the system memory size has changed the first time you start your system.

## Using the System Setup Program Navigation Keys

Keys	Action
Up arrow or <Shift><Tab>	Moves to the previous field.
Down arrow or <Tab>	Moves to the next field.
Spacebar, <+>, <->, left and right arrows	Cycles through the settings in a field. In many fields, you can also type the appropriate value.
<Esc>	Exits the System Setup program and restarts the system if any changes were made.
<F1>	Displays the System Setup program's help file.

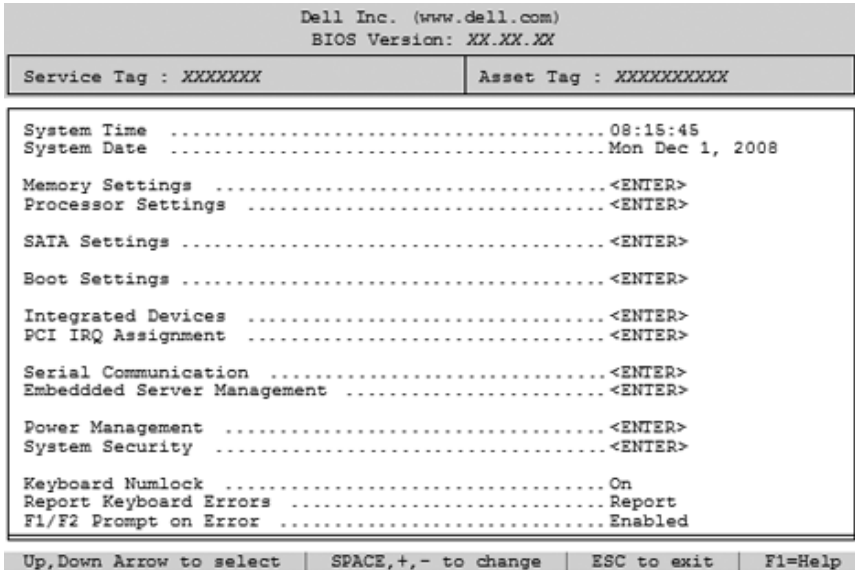


**NOTE:** For most of the options, any changes that you make are recorded but do not take effect until you restart the system.

# System Setup Options

## Main Screen

Figure 2-1. Main System Setup Program Screen




**NOTE:** The options for the System Setup program change based on the system configuration.



**NOTE:** The System Setup program defaults are listed under their respective options in the following sections, where applicable.

Option	Description
System Time	Sets the time on the system's internal clock.
System Date	Sets the date on the system's internal calendar.
Memory Settings	Displays information related to installed memory. See "Memory Settings Screen" on page 61.

<b>Option</b>	<b>Description</b>
Processor Settings	Displays information related to processors (speed, cache size, and so on). See "Processor Settings Screen" on page 62.
SATA Settings	Displays a screen to enable or disable the integrated SATA controller and ports. See "SATA Settings Screen" on page 63.
Boot Settings	Displays a screen to specify the boot mode (BIOS or UEFI). For BIOS boot mode, you can also specify the boot devices. See "Boot Settings Screen" on page 63.
Integrated Devices	Displays a screen to enable or disable integrated device controllers and ports, and to specify related features and options. See "Integrated Devices Screen" on page 64.
PCI IRQ Assignment	Displays a screen to change the IRQ assigned to each of the integrated devices on the PCI bus, and any installed expansion card that requires an IRQ. See "PCI IRQ Assignments Screen" on page 65.
Serial Communication	Displays a screen to enable or disable the serial ports and specify related features and options. See "Serial Communication Screen" on page 66.
Embedded Server Management	Displays a screen to configure the front-panel LCD options and to set a user-defined LCD string. See "Embedded Server Management Screen" on page 67.
Power Management	Enables you to manage power usage of the processor(s), fans, and memory modules with preconfigured or customized settings. See "Power Management Screen" on page 67.
System Security	Displays a screen to configure the system password and setup password features. See "System Security Screen" on page 68, "Using the System Password" on page 73, and "Using the Setup Password" on page 75 for more information.
Keyboard NumLock (On default)	Determines whether your system starts up with the NumLock mode activated on 101- or 102-key keyboards (does not apply to 84-key keyboards).

Option	Description
Report Keyboard Errors ( <b>Report</b> default)	Enables or disables reporting of keyboard errors during the POST. Select <b>Report</b> for host systems that have keyboards attached. Select <b>Do Not Report</b> to suppress all error messages relating to the keyboard or keyboard controller during POST. This setting does not affect the operation of the keyboard itself if a keyboard is attached to the system.
F1/F2 Prompt on Error ( <b>Enabled</b> default)	Enables the system to halt on errors during POST, which allows the user to observe events that may scroll by unnoticed during normal POST. The user can press <F1> to continue or <F2> to enter the System Setup program.   <b>CAUTION: When setting this option to Disabled, the system will not halt if an error occurs during POST. Any critical errors will be displayed and logged in the system event log.</b>

## Memory Settings Screen

Option	Description
System Memory Size	Displays the amount of system memory.
System Memory Type	Displays the type of system memory.
System Memory Speed	Displays the system memory speed.
Video Memory	Displays the amount of video memory.
System Memory Testing ( <b>Enabled</b> default)	Specifies whether system memory tests are run at system boot. Options are <b>Enabled</b> and <b>Disabled</b> .
Memory Operating Mode	This field displays the type of memory operation if a valid memory configuration is installed. When set to <b>Optimizer Mode</b> , the memory controllers run independently of each other for improved memory performance. When set to <b>Mirror Mode</b> , memory mirroring is enabled. When set to <b>Advanced ECC Mode</b> , two controllers are joined in 128-bit mode running multi-bit advanced ECC. For information about the memory modes, see "System Memory" on page 130.

Option	Description
Node Interleaving (Disabled default)	If this field is <b>Enabled</b> , memory interleaving is supported if a symmetric memory configuration is installed. If <b>Disabled</b> , the system supports Non-Uniform Memory architecture (NUMA) (asymmetric) memory configurations.


## Processor Settings Screen

Option	Description
64-bit	Specifies if the processor(s) support 64-bit extensions.
Core Speed	Displays the processor clock speed.
Bus Speed	Displays the processor bus speed.
Logical Processor (Enabled default)	On processors that support Simultaneous Multi-Threading (SMT) technology, each processor core supports up to two logical processors. If this field is set to <b>Enabled</b> , the BIOS reports both logical processors. If set to <b>Disabled</b> , only one logical processor is monitored by the BIOS.
Virtualization Technology (Disabled default)	<b>Enabled</b> permits virtualization software to use the virtualization technology incorporated in the processor. <b>NOTE:</b> Disable this feature if your system will not be running virtualization software.
Execute Disable (Enabled default)	Enables or disables <b>Execute Disable Memory Protection Technology</b> .
Number of Cores per Processor (All default)	If set to <b>All</b> , the maximum number of cores in each processor is enabled.
Turbo Mode	If Turbo Boost Technology is supported by the processor(s), enables or disables <b>Turbo Mode</b> .
C States (Enabled default)	When set to <b>Enabled</b> , the processor(s) can operate in all available power states.
Processor X ID	Displays the family, model, Level 2 cache size, Level 3 cache size, and number of cores of each processor.

## SATA Settings Screen

Option	Description
Embedded SATA (ATA Mode default)	<b>ATA Mode</b> enables the integrated SATA controller. <b>Off</b> disables the controller.
Port A (Auto default)	<b>Auto</b> enables BIOS support for the device attached to SATA port A. <b>Off</b> disables BIOS support for the device.
Port B (Off default)	<b>Auto</b> enables BIOS support for the device attached to SATA port B. <b>Off</b> disables BIOS support for the device.

## Boot Settings Screen

Option	Description
Boot Mode (BIOS default)	 <b>CAUTION: Switching the boot mode could prevent the system from booting if the operating system was not installed in the same boot mode.</b>  If the system operating system supports Unified Extensible Firmware Interface, you can set this option to <b>UEFI</b> . Setting this field to <b>BIOS</b> allows compatibility with non-UEFI operating systems.  <b>NOTE:</b> Setting this field to <b>UEFI</b> disables the <b>Boot Sequence</b> , <b>Hard-Disk Drive Sequence</b> , and <b>USB Flash Drive Emulation Type</b> fields.
Boot Sequence	If <b>Boot Mode</b> is set to <b>BIOS</b> , this field tells the system where the operating system files needed for startup are located. If <b>Boot Mode</b> is set to <b>UEFI</b> , you can access the UEFI boot manager utility by rebooting the system and pressing <F11> when prompted to do so.
Hard-Disk Drive Sequence	Determines the order in which the BIOS will attempt to boot from hard drives in the system during system startup.

<b>Option</b>	<b>Description</b>
USB Flash Drive Emulation Type (Auto default)	Determines the emulation type for a USB flash drive. <b>Hard disk</b> allows the USB flash drive to act as a hard drive. <b>Floppy</b> allows the USB flash drive to act as a removable diskette drive. <b>Auto</b> automatically chooses an emulation type.  <b>Auto</b> automatically chooses the appropriate emulation type for the device, except for devices installed in the internal SD card slot. A device installed in the internal SD card slot will automatically emulate a hard drive. If you install a device in this slot that is configured as a removable diskette drive, you must manually set the emulation type to <b>Floppy</b> .
Boot Sequence Retry (Disabled default)	If this field is enabled and the system has failed to boot, the system will reattempt to boot after 30 seconds.

## Integrated Devices Screen

<b>Option</b>	<b>Description</b>
Integrated SAS/RAID Controller (Enabled default)	Enables or disables the integrated storage controller.
User Accessible USB Ports (All Ports On default)	Enables or disables the user-accessible USB ports. Options are <b>All Ports On</b> , <b>Only Back Ports On</b> , and <b>All Ports Off</b> .
Internal USB Port (On default)	Enables or disables the internal USB port.
Internal SD Card Port	Enables or disables the internal SD card port.
Embedded NIC1 and NIC2 Embedded NIC3 and NIC4	Enables or disables the OS interface of the four embedded NICs. (The NICs may also be accessed through the system's management controller.)
Embedded Gb NICx (NIC1 default: <b>Enabled with PXE</b> ; Other NICs: <b>Enabled</b> )	Enables or disables the embedded NICs. Options are <b>Enabled</b> , <b>Enabled with PXE</b> , <b>Enabled with iSCSI Boot</b> , and <b>Disabled</b> . PXE support allows the system to boot from the network.
MAC Address	Displays the MAC address for the NIC.



Option	Description
Capability Detected	Displays the features of the NIC hardware key, if installed. <b>NOTE:</b> Some NIC features may require the installation of an additional driver.
OS Watchdog Timer (Disabled default)	Sets a timer to monitor the operating system for activity, and aids in recovery if the system stops responding. When <b>Enabled</b> , the operating system is allowed to initialize the timer. When <b>Disabled</b> , the timer is not initialized. <b>NOTE:</b> This feature is usable only with operating systems that support WDAT implementations of the Advanced Configuration and Power Interface (ACPI) 3.0b specification.
I/OAT DMA Engine (Disabled default)	Enables or disables the I/O Acceleration Technology feature.
Embedded Video Controller (Enabled default)	Enables or disables BIOS support for the integrated video controller. <b>NOTE:</b> This field can be disabled only if an add-in video card is present. If this field is disabled, remote access features such as virtual KVM are not available.

## PCI IRQ Assignments Screen

Option	Description
<PCIe device>	Use the <+> and <-> keys to manually select an IRQ for a given device, or select <b>Default</b> to allow the BIOS to select an IRQ value at system startup.

## Serial Communication Screen

Option	Description
Serial Communication ( <b>On without Console Redirection</b> default)	Selects whether the serial communication devices ( <b>Serial Device 1</b> and <b>Serial Device 2</b> ) are enabled in BIOS. BIOS console redirection can also be enabled and the port address used can be specified.  Options are <b>On without Console Redirection</b> , <b>On with Console Redirection via COM1</b> , <b>On with Console Redirection via COM2</b> , and <b>Off</b> .
Serial Port Address ( <b>Serial Device 1=COM1, Serial Device2=COM2</b> default)	Sets the serial port addresses for the two serial devices. <b>NOTE:</b> Only <b>Serial Device 2</b> can be used for <b>Serial Over LAN (SOL)</b> . To use console redirection by <b>SOL</b> , configure the same port address for console redirection and the serial device.
External Serial Connector	Specifies whether <b>Serial Device 1</b> , <b>Serial Device 2</b> , or <b>Remote Access Device</b> has access to the external serial connector. <b>NOTE:</b> Only <b>Serial Device 2</b> can be used for <b>Serial Over LAN (SOL)</b> . To use console redirection by <b>SOL</b> , configure the same port address for console redirection and the serial device.
Failsafe Baud Rate ( <b>115200</b> default)	Displays the failsafe baud rate used for console redirection. BIOS attempts to determine the baud rate automatically. This failsafe baud rate is used only if the attempt fails. This rate should not be adjusted.
Remote Terminal Type ( <b>VT 100/VT220</b> default)	Sets the remote console terminal type, either <b>VT100/VT220</b> or <b>ANSI</b> .
Redirection After Boot ( <b>Enabled</b> default)	Enables or disables BIOS console redirection when the operating system is loaded.

## Embedded Server Management Screen

Option	Description
Front Panel LCD Options	<p>Options are <b>User Defined String</b>, <b>Model Number</b>, or <b>None</b>.</p> <p>If the LCD Home screen is set to an option other than these three choices, the option will be displayed as "Advanced" in the BIOS. In this event, the option cannot be changed in the BIOS unless it is changed back to <b>User Defined String</b>, <b>Model Number</b>, or <b>None</b> through another LCD configuration utility (such as the iDRAC Configuration Utility or the LCD panel menu).</p>
User-Defined LCD String	<p>You can enter a name or other identifier for the system, to be displayed on the LCD module screen.</p>


## Power Management Screen


Option	Description
Power Management	<p>Options are <b>OS Control</b>, <b>Active Power Controller</b>, <b>Custom</b>, or <b>Maximum Performance</b>. For all but the <b>Custom</b> setting, the BIOS pre-configures the power settings on this screen as follows:</p> <ul style="list-style-type: none"><li>• <b>OS Control</b> sets the CPU power to <b>OS DBPM</b>, the fan power to <b>Minimum Power</b>, and the memory power to <b>Maximum Performance</b>. In this setting, all processor performance information is passed from the system BIOS to the operating system for control. The operating system sets the processor performance based on processor utilization.</li><li>• <b>Active Power Controller</b> sets the CPU power to <b>System DBPM</b>, the fan power to <b>Minimum Power</b>, and the memory power to <b>Maximum Performance</b>. The BIOS sets the processor performance based on processor utilization.</li><li>• <b>Maximum Performance</b> sets all fields to <b>Maximum Performance</b>.</li></ul> <p>If you select <b>Custom</b>, you can configure each option independently.</p>

<b>Option</b>	<b>Description</b>
CPU Power and Performance Management	Options are <b>OS DBPM</b> , <b>System DBPM</b> , <b>Maximum Performance</b> , or <b>Minimum Power</b> .
Fan Power and Performance Management	Options are <b>Maximum Performance</b> or <b>Minimum Power</b> .
Memory Power and Performance Management	Options are <b>Maximum Performance</b> , a specified frequency, or <b>Minimum Power</b> .

## **System Security Screen**

<b>Option</b>	<b>Description</b>
System Password	Displays the current status of the password security feature and allows a new system password assignment and verification. <b>NOTE:</b> See "Using the System Password" on page 73 for more information.
Setup Password	Restricts access to the System Setup program by using a setup password. <b>NOTE:</b> See "Using the System Password" on page 73 for more information.
Password Status (Unlocked default)	When <b>Setup Password</b> is assigned and this field is <b>Locked</b> , the system password cannot be changed or disabled at system start-up. See "Using the System Password" on page 73 for more information.

Option	Description
TPM Security (Off default)	<p>Sets the reporting of the Trusted Platform Module (TPM) in the system.</p> <p>If <b>Off</b>, the presence of the TPM is not reported to the operating system.</p> <p>If <b>On with Pre-boot Measurements</b>, the system reports the TPM to the operating system and stores the pre-boot measurements to the TPM during POST.</p> <p>If <b>On without Pre-boot Measurements</b>, the system reports the TPM to the operating system and bypasses pre-boot measurements.</p>
TPM Activation (No Change default)	<p>When set to <b>Activate</b>, the TPM is enabled to default settings. When set to <b>Deactivate</b>, the TPM is disabled. The <b>No Change</b> state initiates no action. The operational state of the TPM remains unchanged (all user settings for the TPM are preserved).</p> <p><b>NOTE:</b> This field is read-only when <b>TPM Security</b> is set to <b>Off</b>.</p>
TPM Clear (No default)	<p> <b>CAUTION: Clearing the TPM will lose all encryption keys in the TPM. This option prevents booting to the operating system and results in data loss if the encryption keys cannot be restored. Back up the TPM keys prior to enabling this option.</b></p> <p>When set to <b>Yes</b>, all TPM contents are cleared.</p> <p><b>NOTE:</b> This field is read-only when <b>TPM Security</b> is set to <b>Off</b>.</p>
Power Button (Enabled default)	<p>If <b>Enabled</b>, the power button can turn the system's power off and on. On an ACPI-compliant operating system, the system performs an orderly shutdown before power is turned off.</p> <p>When <b>Disabled</b>, the button can only turn on system power.</p>


Option	Description
NMI Button (Disabled default)	 <b>CAUTION: Use the NMI button only if directed to do so by qualified support personnel or by the operating system's documentation. Pressing this button halts the operating system and displays a diagnostic screen.</b>  Enables or disables the NMI feature.
AC Power Recovery (Last default)	Determines how the system reacts when power is restored. If set to <b>Last</b> , the system returns to the last power state. <b>On</b> turns on the system after power is restored. <b>Off</b> allows the system to remain off after power is restored.
AC Power Recovery Delay	Determines when the system restarts after power is restored. Options are <b>Immediate</b> , <b>Random</b> (a random value of 30 to 240 seconds), or a user-defined value of 30 to 240 seconds.

## Exit Screen

Press <Esc> to exit the System Setup program; the **Exit** screen displays:

- Save Changes and Exit
- Discard Changes and Exit
- Return to Setup

## Entering the UEFI Boot Manager

 **NOTE:** Operating systems must be 64-bit UEFI-compatible (for example, Microsoft Windows Server 2008 x64 version) to be installed from the UEFI boot mode. DOS and 32-bit operating systems can only be installed from the BIOS boot mode.


 **NOTE:** The Boot Mode must be set to **UEFI** in the System Setup program to access the UEFI Boot Manager.

The UEFI Boot Manager enables you to:

- Add, delete, and arrange boot options
- Access the System Setup program and BIOS-level boot options without rebooting

- 1 Turn on or restart your system.
- 2 Press <F11> after you see the following message:

<F11> = UEFI Boot Manager

 **NOTE:** The system will not respond until the USB keyboard is active.

If your operating system begins to load before you press <F11>, allow the system to finish booting, and then restart your system and try again.

## Using the UEFI Boot Manager Navigation Keys

Keys	Action
Up arrow	Moves to and highlights the previous field.
Down arrow	Moves to and highlights the next field.
Spacebar, <Enter>, <+>, <->, <Esc>	Cycles through the settings in a field.
<Esc>	Refreshes the UEFI Boot Manager screen, or returns to the UEFI Boot Manager screen from the other program screens.
<F1>	Displays the UEFI Boot Manager help file.

## UEFI Boot Manager Screen

Option	Description
Continue	The system attempts to boot to devices starting with the first item in the boot order. If the boot attempt fails, the system will continue with the next item in the boot order until the boot is successful or no more boot options are found.
<Boot options>	Displays the list of available boot options (marked with asterisks). Select the boot option you wish to use and press Enter. <b>NOTE:</b> If you hot-add a boot device, press <ESC> to refresh the list of boot options.

<b>Option</b>	<b>Description</b>
UEFI Boot Settings	Enables you to add, delete, enable, or disable boot options; change boot order; or execute a one-time boot option.
System Utilities	Enables you to access the System Setup program, System Services, and BIOS-level boot options.

## **UEFI Boot Settings Screen**

<b>Option</b>	<b>Description</b>
Add Boot Option	Adds a new boot option.
Delete Boot Option	Deletes an existing boot option.
Enable/Disable Boot Option	Disables and enables a boot option in the boot option list.
Change Boot Order	Changes the order of the boot option list.
One-Time Boot From File	Sets a one-time boot option not included in the boot option list.

## **System Utilities Screen**

<b>Option</b>	<b>Description</b>
System Setup	Accesses the System Setup program without rebooting.
System Services	Restarts the system and accesses the Unified Server Configurator, which enables you to run utilities such as system diagnostics.
BIOS Boot Manager	Accesses the BIOS-level boot options list without rebooting. This option enables you to conveniently switch to BIOS boot mode if you need to boot to a device with a non-UEFI operating system, such as a bootable DOS media with diagnostics software.
Reboot System	Restarts the system.



# System and Setup Password Features



**NOTE:** For a forgotten password, see "Disabling a Forgotten Password" on page 186.

Your system is shipped without the system password feature enabled in BIOS.



**CAUTION:** Anyone can access the data stored on your system if the system is running and unattended.

## Using the System Password

When a system password is assigned, the system prompts for the system password after the system starts and only those with the password have full use of the system.

### Assigning a System Password

Before assigning a system password, enter the System Setup program and check the **System Password** option.

When a system password is assigned, **System Password is Enabled**. If **Password Status is Unlocked**, you can change the system password. If **Locked**, you cannot change the system password. Disabling the password jumper on the system board sets **System Password to Disabled**, and you cannot change or enter a new system password.

When a system password is not assigned and the password jumper on the system board is in the enabled position, **System Password is Not Enabled** and **Password Status is Unlocked**. To assign a system password:

- 1 Verify that **Password Status is Unlocked**.
- 2 Highlight the **System Password** option and press <Enter>.
- 3 Type your new system password.

You can use up to 32 characters in your password.

As you type, placeholders appear in the field.

The password assignment is not case-sensitive. To erase a character, press <Backspace> or the left-arrow key.



**NOTE:** To escape from the field without assigning a system password, press <Enter> to move to another field, or press <Esc> prior to completing step 5.

- 4 Press <Enter>.

- 5 To confirm your password, type it a second time and press <Enter>. **System Password** changes to **Enabled**. Exit the System Setup program and begin using your system.
- 6 Either reboot the system now for the password protection to take effect or continue working.



**NOTE:** Password protection does not take effect until the system reboots.

### Using Your System Password to Secure Your System



**NOTE:** If you have assigned a setup password (see "Using the Setup Password" on page 75), the system accepts your setup password as an alternate system password.

When **Password Status** is **Unlocked**, you have the option to leave the password security enabled or to disable password security.

To leave the password security enabled:

- 1 Turn on or reboot your system by pressing <Ctrl><Alt><Del>.
- 2 Type your password and press <Enter>.

To disable the password security:

- 1 Turn on or reboot your system by pressing <Ctrl><Alt><Del>.
- 2 Type your password and press <Ctrl><Enter>.

When **Password Status** is **Locked**, you must type the password and press <Enter> when prompted at reboot.

If an incorrect system password is entered, the system displays a message and prompts you to re-enter your password. You have three attempts to enter the correct password. After the third unsuccessful attempt, the system displays an error message that the system has halted and must be shut down manually with the power button. Even after you shut down and restart the system, the error message continues to be displayed until the correct password is entered.



**NOTE:** You can use the **Password Status** option in conjunction with the **System Password** and **Setup Password** options to protect your system from unauthorized changes.

## Changing an Existing System Password

- 1 Enter the System Setup program by pressing <F2> during POST.
- 2 Select the System Security screen.
- 3 Verify that the Password Status is Unlocked.
- 4 Type the new system password in the two password fields.

The System Password field changes to Not Enabled if the password was deleted.

## Disabling the System Password

If the system password is already set, you can disable it by typing the password during POST and pressing <Ctrl><Enter>, or you can enter the System Setup program and press <Enter> twice in the system password menu.

## Using the Setup Password

### Assigning a Setup Password

You can assign a setup password only when the Setup Password is Not Enabled. To assign a setup password, highlight the Setup Password option and press the <+> or <-> key. The system prompts you to enter and verify the password.



**NOTE:** The setup password can be the same as the system password. If the two passwords are different, the setup password can be used as an alternate system password. The system password cannot be used in place of the setup password.

You can use up to 32 characters in your password.

As you type, placeholders appear in the field.

The password assignment is not case-sensitive. To erase a character, press <Backspace> or the left-arrow key.

When you verify the password, the Setup Password changes to Enabled. The next time you enter the System Setup program, the system prompts you for the setup password.

A change to the Setup Password option becomes effective immediately (restarting the system is not required).

## Operating With a Setup Password Enabled

If **Setup Password** is **Enabled**, you must enter the correct setup password before modifying most of the System Setup options.

If you do not enter the correct password in three attempts, the system lets you view, but not modify, the System Setup screens. The following options are exceptions: If **System Password** is not **Enabled** and is not locked through the **Password Status** option, you can assign a system password. You cannot disable or change an existing system password.



**NOTE:** You can use the **Password Status** option in conjunction with the **Setup Password** option to protect the system password from unauthorized changes.

## Deleting or Changing an Existing Setup Password

- 1 Enter the System Setup program and select the **System Security**.
- 2 Highlight **Setup Password**, press <Enter> to access the setup password window. Press <Enter> twice to clear the existing setup password.  
The setting changes to **Not Enabled**.
- 3 If you want to assign a new setup password, perform the steps in "Assigning a Setup Password" on page 75.

## iDRAC Configuration Utility

The iDRAC Configuration Utility is a pre-boot configuration environment that allows you to view and set parameters for the iDRAC6 and for the managed server. The iDRAC Configuration Utility enables you to:

- Configure, enable, or disable the iDRAC6 local area network through the dedicated iDRAC6 Enterprise card port or the embedded NICs.
- Enable or disable IPMI over LAN.
- Enable a LAN Platform Event Trap (PET) destination.
- Attach or detach the Virtual Media devices.
- Change the administrative username and password and manage user privileges.
- View System Event Log (SEL) messages or clear messages from the log.

For additional information on using iDRAC6, see the documentation for iDRAC6 and systems management applications.

## Entering the iDRAC Configuration Utility

- 1 Turn on or restart your system.
- 2 Press <Ctrl><E> when prompted during POST.

If your operating system begins to load before you press <Ctrl><E>, allow the system to finish booting, and then restart your system and try again.



# Installing System Components

## Recommended Tools

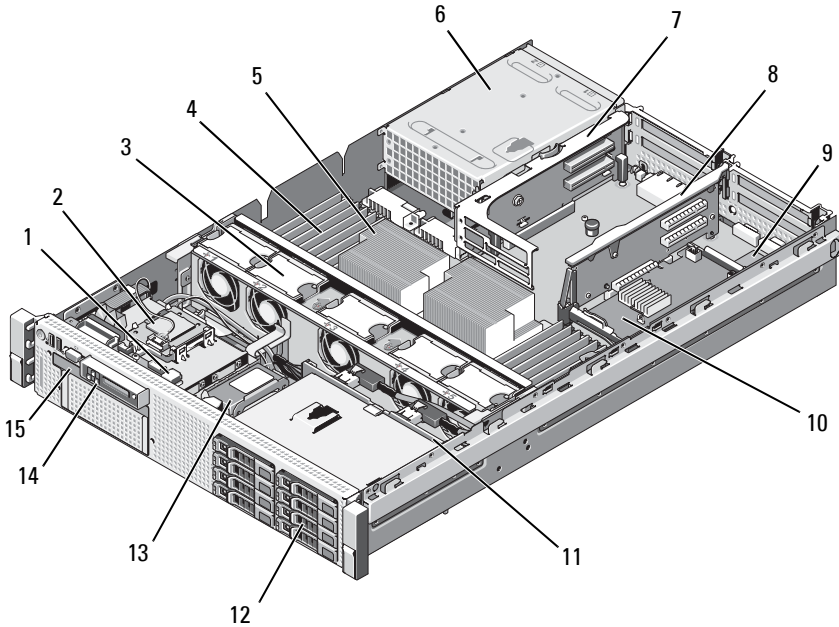
- Key to the system keylock
- #1 and #2 Phillips screwdrivers
- Wrist grounding strap
- T8, T10, and T15 Torx drivers

## Inside the System



**CAUTION: Many repairs may only be done by a certified service technician. You should only perform troubleshooting and simple repairs as authorized in your product documentation, or as directed by the online or telephone service and support team. Damage due to servicing that is not authorized by Dell is not covered by your warranty. Read and follow the safety instructions that came with the product.**

**Figure 3-1. Inside the System**



- |    |   |    |                                    |
|----|---|----|------------------------------------|
| 1  | USB connector for optional internal USB key | 2  | Internal SD Module                 |
| 3  | hot-swappable cooling fans (4 or 5)         | 4  | memory modules (up to 18 total)    |
| 5  | processor                                   | 6  | power supply bays (2)              |
| 7  | riser 2 (PCIe slots 3 and 4)                | 8  | riser 1 (PCIe slots 1 and 2)       |
| 9  | iDRAC6 Enterprise card (optional)           | 10 | integrated storage controller card |
| 11 | SAS backplane                               | 12 | SAS or SATA hard drives (up to 6)  |
| 13 | RAID battery (PERC only)                    | 14 | control panel                      |
| 15 | slimline optical drive                      |    |                                    |



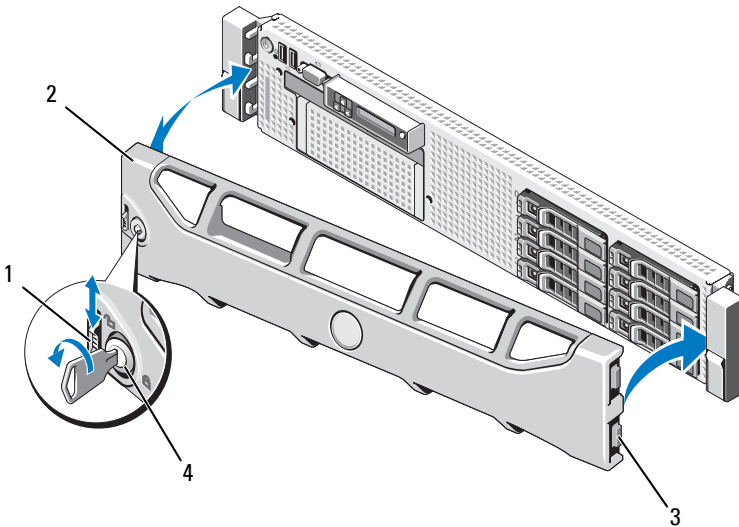
## Front Bezel (Optional)

A lock on the bezel restricts access to the power button, optical drive, and hard drive(s). The LCD panel and navigation buttons are accessible through the front bezel. See Figure 3-2.

### Removing the Front Bezel

- 1 Using the system key, unlock the bezel.
- 2 Pull up on the release latch next to the key lock.
- 3 Rotate the left end of the bezel away from the system to release the right end of the bezel.
- 4 Pull the bezel away from the system. See Figure 3-2.

**Figure 3-2. Removing the Front Bezel**



1 release latch

3 hinge tabs

2 bezel

4 key lock

## Installing the Front Bezel

- 1 Insert the hinge tab on the right of the bezel into the slot on the right side of the system front panel.
- 2 Rotate the left side of the bezel toward the system.
- 3 Press the bezel to the system to engage the latch.

## Information Tag

The information tag is a slide-out label panel for system information including the Express Service tag, Embedded NIC1 MAC address, and iDRAC6 Enterprise card MAC address.


### Removing the Information Tag


- 1 Remove the front bezel. See "Removing the Front Bezel" on page 81.
- 2 Pull the information tag out of its slot in the chassis until it is in the locked position. See Figure 1-1 for the location of the information tag slot.
- 3 Pull down on the tag until it disengages from the slot in the chassis to release the top portion of the tag.
- 4 Pull up on the tag until it disengages from the slot in the chassis to release the bottom portion of the tag.
- 5 Remove the tag.

### Replacing the Information Tag

- 1 Remove the front bezel. See "Removing the Front Bezel" on page 81.
- 2 Locate the information tag slot on the front of the system chassis. See Figure 1-1 for the location of the information tag slot.
- 3 Holding the information tag vertically, slide it into the information tag slot until it locks into place.

## Opening and Closing the System

 **CAUTION:** Many repairs may only be done by a certified service technician. You should only perform troubleshooting and simple repairs as authorized in your product documentation, or as directed by the online or telephone service and support team. Damage due to servicing that is not authorized by Dell is not covered by your warranty. Read and follow the safety instructions that came with the product.

 **WARNING:** Whenever you need to lift the system, get others to assist you. To avoid injury, do not attempt to lift the system by yourself.

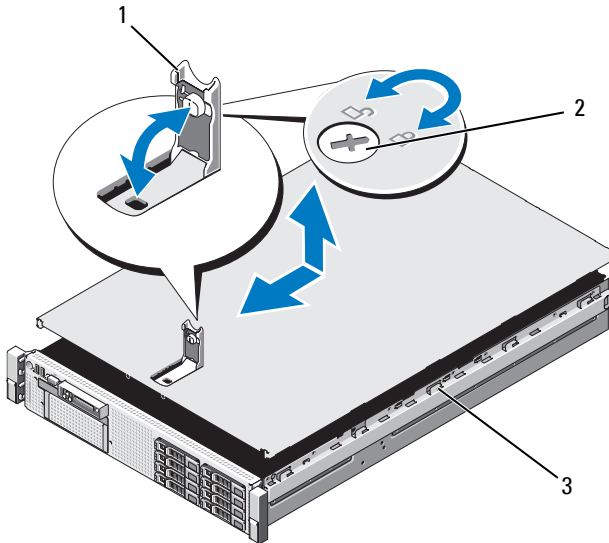
### Opening the System

- 1 Unless you are installing a hot-swappable component such as a cooling fan or power supply, turn off the system and attached peripherals, and disconnect the system from the electrical outlet and peripherals.
- 2 Rotate the latch release lock counter-clockwise to the unlocked position. See Figure 3-3.
- 3 Lift up on the latch on top of the system and slide the cover back. See Figure 3-3.
- 4 Grasp the cover on both sides and lift the cover away from the system.

### Closing the System

- 1 Lift up the latch on the cover.
- 2 Place the cover onto the chassis and offset the cover slightly back so that it clears the chassis hooks and lays flush on the system chassis. See Figure 3-3.
- 3 Push down the latch to lever the cover into the closed position.
- 4 Rotate the latch release lock in a clockwise direction to secure the cover.

**Figure 3-3. Removing or Installing the Cover**



1 latch

2 latch release lock

3 chassis hooks

## Hard Drives

Your system supports:

- Six 3.5-inch drive bays without the flex bay
- Hot-swappable SAS and SATA hard drives.

All drives are installed at the front of the system and connect to the system board through the SAS backplane. Hard drives are supplied in special hot-swappable hard-drive carriers that fit in the hard-drive bays.

**CAUTION:** Before attempting to remove or install a drive while the system is running, see the documentation for the storage controller card to ensure that the host adapter is configured correctly to support hot-swap drive removal and insertion.

**CAUTION:** Do not turn off or reboot your system while the drive is being formatted. Doing so can cause a drive failure.

**NOTE:** Use only drives that have been tested and approved for use with the SAS backplane board.

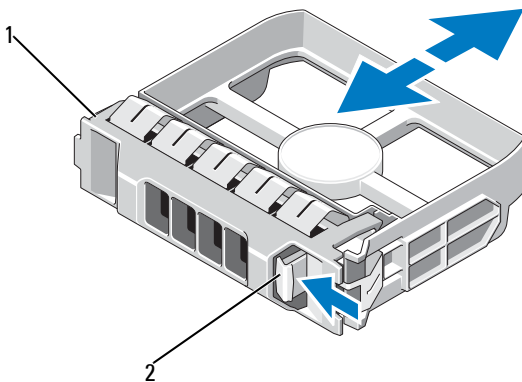
When you format a hard drive, allow enough time for the formatting to be completed. Be aware that high-capacity hard drives can take a number of hours to format.

## Removing a Hard-Drive Blank

**CAUTION:** To maintain proper system cooling, all empty hard-drive bays must have drive blanks installed.

- 1 Remove the front bezel. See "Removing the Front Bezel" on page 81.
- 2 Grasp the front of the hard-drive blank, press the release lever on the right side, and slide the blank out until it is free of the drive bay. See Figure 3-4.

**Figure 3-4. Removing and Installing a Hard Drive Blank**




1 3.5-inch hard drive blank

2 release latch

## Installing a Hard-Drive Blank

Align the hard-drive blank with the drive bay and insert the blank into the drive bay until the release lever clicks into place.


## Removing a Hot-Swap Hard Drive

 **CAUTION:** Ensure that your operating system supports hot-swap drive removal and installation. See the documentation provided with your operating system for more information.

- 1 If present, remove the front bezel. See "Removing the Front Bezel" on page 81.
- 2 From the RAID management software, prepare the drive for removal. Wait until the hard-drive indicators on the drive carrier signal that the drive can be removed safely. See your SAS RAID controller documentation for information about hot-swap drive removal.


If the drive has been online, the green activity/fault indicator will flash as the drive is powered down. When the drive indicators are off, the drive is ready for removal.


- 3 Press the button on the front of the drive carrier and open the drive carrier release handle to release the drive. See Figure 3-5.
- 4 Slide the hard drive out until it is free of the drive bay.

 **CAUTION:** To maintain proper system cooling, all empty hard-drive bays must have drive blanks installed.

- 5 Insert a drive blank in the vacated drive bay. See "Installing a Hard-Drive Blank" on page 86.
- 6 If applicable, install the bezel. See "Installing the Front Bezel" on page 82.

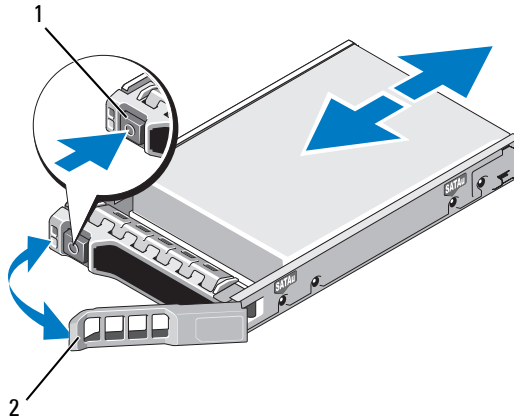
## Installing a Hot-Swap Hard Drive

 **CAUTION:** When installing a hard drive, ensure that the adjacent drives are fully installed. Inserting a hard-drive carrier and attempting to lock its handle next to a partially installed carrier can damage the partially installed carrier's shield spring and make it unusable.

 **CAUTION:** To prevent data loss, ensure that your operating system supports hot-swap drive installation. See the documentation supplied with your operating system.

- 1 If present, remove the front bezel. See "Removing the Front Bezel" on page 81.
- 2 If a drive blank is present in the bay, remove it. See "Removing a Hard-Drive Blank" on page 85.

**Figure 3-5. Installing a Hot-Swap Hard Drive**



1 release button

2 hard drive carrier handle

- 3 Install the hot-swap hard drive.
  - a Press the button on the front of the drive carrier and open the handle.
  - b Insert the hard-drive carrier into the drive bay until the carrier contacts the backplane.
  - c Close the handle to lock the drive in place.
- 4 If applicable, install the bezel. See "Installing the Front Bezel" on page 82.

### Removing a Hard Drive From a Hard-Drive Carrier

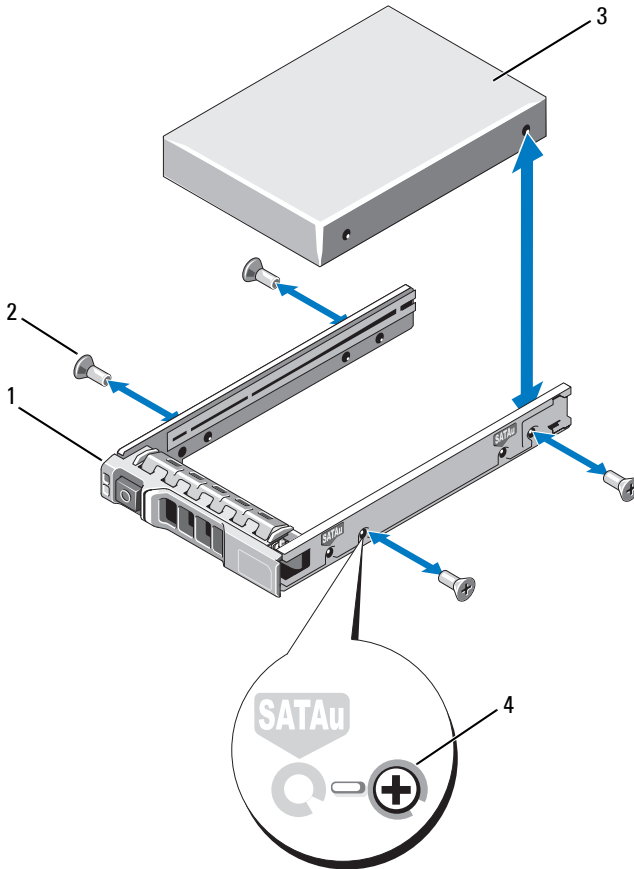
Remove the screws from the slide rails on the hard-drive carrier and separate the hard drive from the carrier. See Figure 3-6.

## **Installing a Hard Drive Into a Hard-Drive Carrier**

- 1** Insert the hard drive into the hard-drive carrier with the connector end of the drive at the back. See Figure 3-6.
- 2** Align the screw holes on the hard drive with the back set of holes on the hard drive carrier.  
When aligned correctly, the back of the hard drive will be flush with the back of the hard-drive carrier.
- 3** Attach the four screws to secure the hard drive to the hard-drive carrier.



**Figure 3-6. Installing a Hard Drive into a Drive Carrier**



- 1 hard-drive carrier
- 3 hard drive

- 2 screws (4)
- 4 SAS screw hole

# Power Supplies

Your system supports the following power supply modules:

- 570-W Energy Smart power supply
- 870-W High Output power supply



**NOTE:** The power supply label specifies the maximum power output.



**NOTE:** The system does not support a mixed installation of High Output and Energy Smart power supplies.

If only one power supply is installed, it must be installed in the PS1 power supply bay.



**CAUTION:** To ensure proper system cooling, the power supply blank must be installed in the PS2 bay in a non-redundant configuration. See "Installing the Power Supply Blank" on page 92.

## Removing a Power Supply



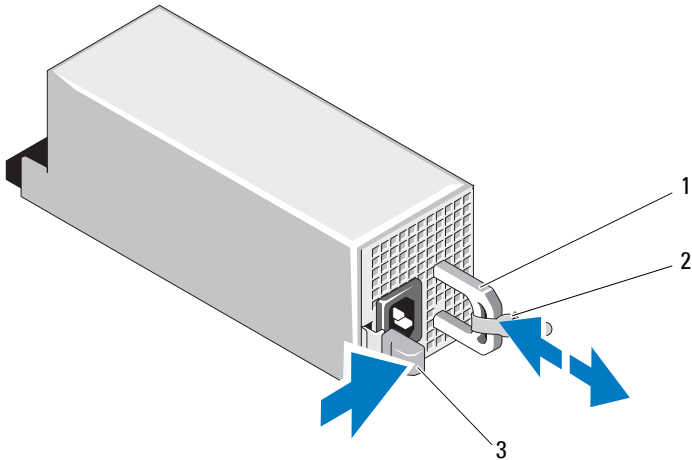
**CAUTION:** If troubleshooting a power supply mismatch error, replace *only* the power supply with the flashing indicator. Swapping the opposite power supply to make a matched pair can result in an error condition and unexpected system shutdown. To change from a High Output configuration to an Energy Smart configuration or vice versa, you must power down the system.



**NOTE:** You may have to unlatch and lift the optional cable management arm if it interferes with power supply removal. For information about the cable management arm, see the system's rack documentation.



- 1 Disconnect the power cable from the power source and the power supply you intend to remove and remove the cables from the Velcro strap.
- 2 Press the lever release latch and slide the power supply out of the chassis. See Figure 3-7.

**Figure 3-7. Removing and Installing a Power Supply**




- 1 power supply handle
- 2 Velcro strap
- 3 release latch

## Replacing a Power Supply

- 1 On a system with redundant power supplies, verify that both power supplies are the same type and have the same maximum output power.
  -  **NOTE:** The maximum output power (shown in watts) is listed on the power supply label.
- 2 Slide the new power supply into the chassis until the power supply is fully seated and the release latch snaps into place. See Figure 3-7.
  -  **NOTE:** If you unlatched the cable management arm in step 2 of the previous procedure, relatch it. For information about the cable management arm, see the system's rack documentation.


- 3 Connect the power cable to the power supply and plug the cable into a power outlet.

 **CAUTION:** When connecting the power cable, secure the cable with the Velcro strap.

 **NOTE:** When installing, hot-swapping, or hot-adding a new power supply, allow several seconds for the system to recognize the power supply and determine its status. The power-supply status indicator turns green to signify that the power supply is functioning properly (see Figure 1-5).

## Removing the Power Supply Blank

If you are installing a second power supply, remove the power supply blank in the bay by pulling outward on the blank.

 **CAUTION:** To ensure proper system cooling, the power supply blank must be installed in the second power supply bay in a non-redundant configuration. Remove the power supply blank only if you are installing a second power supply.


## Installing the Power Supply Blank

 **NOTE:** Install the power supply blank only in the second power supply bay.

To install the power supply blank, align the blank with the power supply bay and insert it into the chassis until it clicks into place.

# Internal SD Module

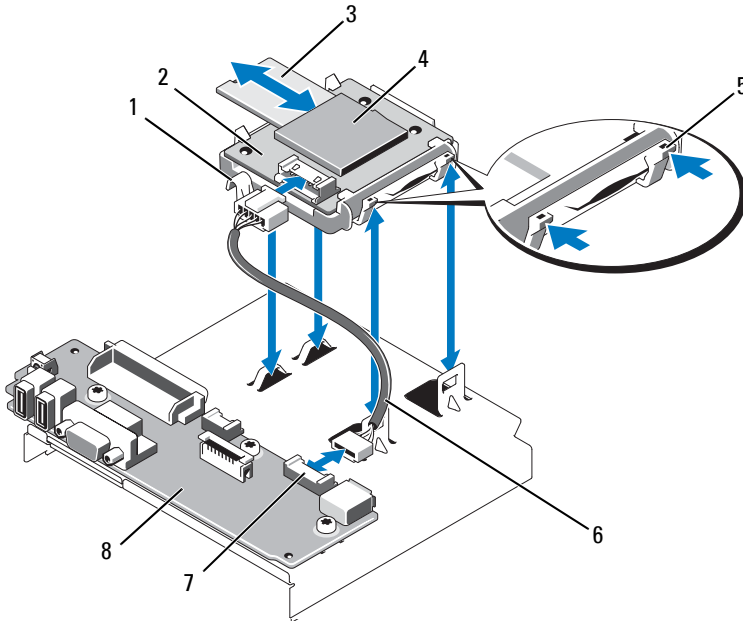
## Installing the Internal SD Module

 **CAUTION:** Many repairs may only be done by a certified service technician. You should only perform troubleshooting and simple repairs as authorized in your product documentation, or as directed by the online or telephone service and support team. Damage due to servicing that is not authorized by Dell is not covered by your warranty. Read and follow the safety instructions that came with the product.

- 1 Turn off the system, including any attached peripherals, and disconnect the system from the electrical outlet.
- 2 Open the system. See "Opening the System" on page 83.

- 3 Position the module so the tabs on the underside of the tray fit into the hooks on the chassis, then lower the opposite edge of the card into place. See Figure 3-8.

**Figure 3-8. Removing or Installing the Internal SD Module**



- |                                |                               |
|--------------------------------|-------------------------------|
| 1 latch                        | 2 internal SD module          |
| 3 SD flash card                | 4 SD card slot (SD connector) |
| 5 release tab                  | 6 internal SD module cable    |
| 7 internal SD module connector | 8 control panel board         |

- 4 Connect the internal SD module cable to the connector on the control panel board. See Figure 3-8.
- 5 Close the system. See "Closing the System" on page 83.
- 6 Reconnect the system and peripherals to their power sources, and turn them on.

## Removing the Internal SD Module



**CAUTION:** Many repairs may only be done by a certified service technician. You should only perform troubleshooting and simple repairs as authorized in your product documentation, or as directed by the online or telephone service and support team. Damage due to servicing that is not authorized by Dell is not covered by your warranty. Read and follow the safety instructions that came with the product.

- 1 Turn off the system, including any attached peripherals, and disconnect the system from the electrical outlet.
- 2 Open the system. See "Opening the System" on page 83.
- 3 Disconnect the cable from the internal SD module and from the control panel board. See Figure 3-8.
- 4 Lift upwards on the latch securing the internal SD module to the chassis, then lift the tray out of the chassis. See Figure 3-8.
- 5 Close the system. See "Closing the System" on page 83.
- 6 Reconnect the system and peripherals to their power sources, and turn them on.

## Internal SD Flash Card

### Installing the Internal SD Flash Card



**CAUTION:** Many repairs may only be done by a certified service technician. You should only perform troubleshooting and simple repairs as authorized in your product documentation, or as directed by the online or telephone service and support team. Damage due to servicing that is not authorized by Dell is not covered by your warranty. Read and follow the safety instructions that came with the product.



**NOTE:** To use an SD card with your system, ensure that the internal SD card port is enabled in the System Setup program. See "Using the System Setup Program and UEFI Boot Manager" on page 57.

- 1 Turn off the system, including any attached peripherals, and disconnect the system from the electrical outlet.
- 2 Open the system. See "Opening the System" on page 83.

- 3 Locate the SD card connector on the internal SD module and, with the label side facing up, insert the contact-pin end of the card into the slot. See Figure 3-8.



**NOTE:** The slot is keyed to ensure correct insertion of the card.

- 4 Press the card into the card slot to lock it into place.
- 5 Close the system. See "Closing the System" on page 83.
- 6 Reconnect the system to power and restart the system.

## Removing the Internal SD Flash Card



**CAUTION:** Many repairs may only be done by a certified service technician. You should only perform troubleshooting and simple repairs as authorized in your product documentation, or as directed by the online or telephone service and support team. Damage due to servicing that is not authorized by Dell is not covered by your warranty. Read and follow the safety instructions that came with the product.

- 1 Turn off the system, including any attached peripherals, and disconnect the system from the electrical outlet.
- 2 Open the system. See "Opening the System" on page 83.
- 3 Locate the SD card slot on the internal SD module and press inward on the card to release it from the slot and remove the card.
- 4 Close the system. See "Closing the System" on page 83.
- 5 Reconnect the system to power and restart the system.

## Internal USB Memory Key

An optional USB memory key installed inside your system can be used as a boot device, security key, or mass storage device. The USB connector must be enabled by the **Internal USB Port** option in the **Integrated Devices** screen of the System Setup program. See "Using the System Setup Program and UEFI Boot Manager" on page 57.

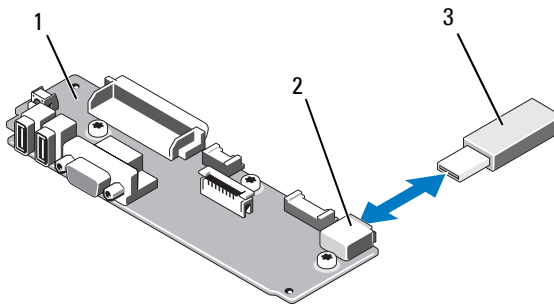
To boot from the USB memory key, configure the USB memory key with a boot image and then specify the USB memory key in the boot sequence in the System Setup program.

**CAUTION:** Many repairs may only be done by a certified service technician. You should only perform troubleshooting and simple repairs as authorized in your product documentation, or as directed by the online or telephone service and support team. Damage due to servicing that is not authorized by Dell is not covered by your warranty. Read and follow the safety instructions that came with the product.

**NOTE:** Maximum dimensions supported for the USB memory key are 24-mm (.94") wide, 79-mm (3.11") long, and 8.6-mm (.33") tall.

- 1 Turn off the system, including any attached peripherals, and disconnect the system from the electrical outlet.
- 2 Open the system. See "Opening the System" on page 83.
- 3 Locate the USB connector on the control panel. See Figure 3-9.
- 4 Insert the USB memory key into the USB connector. See Figure 3-9.

**Figure 3-9. Removing or Installing a USB Memory Key**




- 1 control panel board
- 2 USB memory key connector
- 3 USB memory key

- 5 Close the system. See "Closing the System" on page 83.
- 6 Reconnect the system to power and restart the system.




# Internal USB Cable

## Removing the Internal USB Cable

 **CAUTION: Many repairs may only be done by a certified service technician. You should only perform troubleshooting and simple repairs as authorized in your product documentation, or as directed by the online or telephone service and support team. Damage due to servicing that is not authorized by Dell is not covered by your warranty. Read and follow the safety instructions that came with the product.**

- 1 Turn off the system, including any attached peripherals, and disconnect the system from the electrical outlet.
- 2 Open the system. See "Opening the System" on page 83.
- 3 Remove the fan bracket. See "Removing the Fan Bracket" on page 107.
- 4 Remove the USB cable from the connector on the control panel.
- 5 Remove the USB cable from the cable routing guides on the inside of the chassis. If necessary remove any other cables from the cable routing guides.
- 6 Remove the USB cable from the connector on the system board.

## Installing the Internal USB Cable

 **CAUTION: Many repairs may only be done by a certified service technician. You should only perform troubleshooting and simple repairs as authorized in your product documentation, or as directed by the online or telephone service and support team. Damage due to servicing that is not authorized by Dell is not covered by your warranty. Read and follow the safety instructions that came with the product.**


- 1 Turn off the system, including any attached peripherals, and disconnect the system from the electrical outlet.
- 2 Open the system. See "Opening the System" on page 83.
- 3 Remove the fan bracket. See "Removing the Fan Bracket" on page 107.
- 4 Connect the USB cable to the connector on the control panel.
- 5 Route the cable through the cable routing guides on the inside of the chassis.
- 6 Connect the USB cable to the connector on the system board.
- 7 Replace the fan bracket. See "Replacing the Fan Bracket" on page 108.

- 8 Close the system. See "Closing the System" on page 83.
- 9 Reconnect the system and peripherals to their power sources, and turn them on.

## Integrated Dell Remote Access Controller 6 (iDRAC6) Enterprise Card (Optional)

The optional iDRAC6 Enterprise card provides a set of advanced features for managing the server remotely.

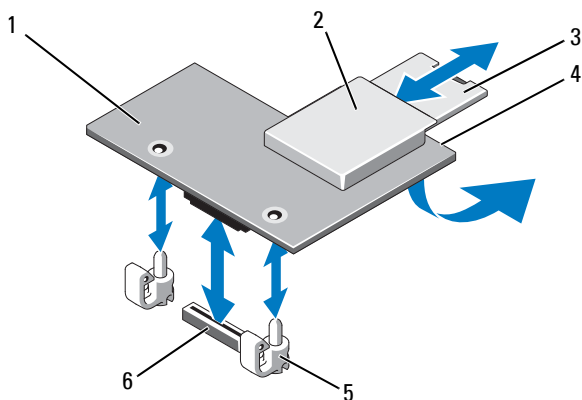
### Installing an iDRAC6 Enterprise Card

 **CAUTION: Many repairs may only be done by a certified service technician. You should only perform troubleshooting and simple repairs as authorized in your product documentation, or as directed by the online or telephone service and support team. Damage due to servicing that is not authorized by Dell is not covered by your warranty. Read and follow the safety instructions that came with the product.**

- 1 Turn off the system, including any attached peripherals, and disconnect the system from the electrical outlet.
- 2 Open the system. See "Opening the System" on page 83.
- 3 Remove the plastic filler plug for the iDRAC6 Enterprise port from the system back panel. See "Back Panel Features and Indicators" on page 19 for the port location.
- 4 If installed, remove all expansion cards from expansion-card riser 1. See "Removing an Expansion Card" on page 123.
- 5 Install the iDRAC6 Enterprise card:
  - a Angle the card so that the RJ-45 connector fits through the back-panel opening. See Figure 3-10.
  - b Align the front edge of the card with the two front plastic retention standoffs next to the iDRAC6 connector on the system board. See Figure 6-2 for the location of the connector.
  - c Press the card down until it is fully seated. See Figure 3-10.  
When the front of the card is fully seated, the plastic standoffs snap over the edge of the card.

- 6 Reinstall all expansion cards in expansion-card riser 1. See "Installing an Expansion Card" on page 121.
- 7 Close the system. See "Closing the System" on page 83.
- 8 Reconnect the system and peripherals to their power sources, and turn them on.

**Figure 3-10. Removing and Installing the iDRAC6 Enterprise Card**



- |                                |   |
|--------------------------------|---|
| 1 iDRAC6 Enterprise card       | 2 VFlash media slot                     |
| 3 VFlash SD card               | 4 RJ-45 Ethernet port (underneath card) |
| 5 retention standoff posts (2) | 6 iDRAC6 Enterprise card connector      |

## Removing an iDRAC6 Enterprise Card

**CAUTION:** Many repairs may only be done by a certified service technician. You should only perform troubleshooting and simple repairs as authorized in your product documentation, or as directed by the online or telephone service and support team. Damage due to servicing that is not authorized by Dell is not covered by your warranty. Read and follow the safety instructions that came with the product.

- 1 Turn off the system, including any attached peripherals, and disconnect the system from the electrical outlet.
- 2 Open the system. See "Opening the System" on page 83.

- 3 If installed, remove all expansion cards from expansion-card riser 1. See "Removing an Expansion Card" on page 123.
- 4 Remove the VFlash media card (if installed) from the iDRAC6 Enterprise card. See "VFlash Media (Optional)" on page 100.
- 5 If present, disconnect the Ethernet cable from the iDRAC6 Enterprise card.
- 6 Remove the iDRAC6 Enterprise card:
  - a Pull back slightly on the two tabs at the front edge of the card and gently lift the front edge of the card off of the retention standoffs.
  - b As the card releases from the standoffs, the connector under the card disengages from the system board connector.
  - c Slide the card away from the back of the system until the RJ-45 connector is clear of the back panel, then lift the card out of the system.
- 7 Install the plastic filler plug for the vacated RJ-45 Ethernet port in the system back panel.
- 8 Reinstall the expansion card(s) in expansion-card riser 1. See "Installing an Expansion Card" on page 121.
- 9 Close the system. See "Closing the System" on page 83.
- 10 Reconnect the system and peripherals to their power sources, and turn them on.

## VFlash Media (Optional)

The optional VFlash media is a Secure Digital (SD) card that can be used with the optional iDRAC6 Enterprise card. See "Integrated Dell Remote Access Controller 6 (iDRAC6) Enterprise Card (Optional)" on page 98.

- 1 Locate the VFlash media slot on the back of the system and insert the contact-pin end of the SD card (with the label side facing up) into the slot. See "Back Panel Features and Indicators" on page 19 for the slot location.



**NOTE:** The slot is keyed to ensure correct insertion of the card.

- 2 Press inward on the card to lock it into the slot.

To remove the card, push inward on the card to release it, and pull the card from the card slot.

# NIC Hardware Key

iSCSI and other future functionalities for the system's embedded NICs are enabled by installing an optional NIC hardware key in the ISCSI\_KEY socket on the system board.



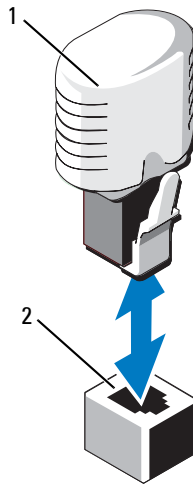
**CAUTION:** Many repairs may only be done by a certified service technician. You should only perform troubleshooting and simple repairs as authorized in your product documentation, or as directed by the online or telephone service and support team. Damage due to servicing that is not authorized by Dell is not covered by your warranty. Read and follow the safety instructions that came with the product.



**NOTE:** When future NIC functionality is supported, you must replace the original NIC hardware key (if installed) with a new hardware key.

- 1 Turn off the system, including any attached peripherals, and disconnect the system from the electrical outlet.
- 2 Open the system. See "Opening the System" on page 83.
- 3 Locate the ISCSI\_KEY connector on the system board. See Figure 6-2.
- 4 Insert the NIC hardware key into the connector onto the board. See Figure 3-11.

**Figure 3-11. Removing or Installing a NIC Hardware Key**




- 1 NIC hardware key
  - 2 ICSI\_KEY connector
- 5 Close the system. See "Closing the System" on page 83.
  - 6 Reconnect the system to the electrical outlet and turn on the system and attached peripherals.

## Cooling Shroud


The system provides a cooling shroud that directs airflow from the cooling fans over the system processor and memory module(s).

**CAUTION:** Many repairs may only be done by a certified service technician. You should only perform troubleshooting and simple repairs as authorized in your product documentation, or as directed by the online or telephone service and support team. Damage due to servicing that is not authorized by Dell is not covered by your warranty. Read and follow the safety instructions that came with the product.

**WARNING:** The memory modules are hot to the touch for some time after the system has been powered down. Allow the memory modules to cool before handling them.

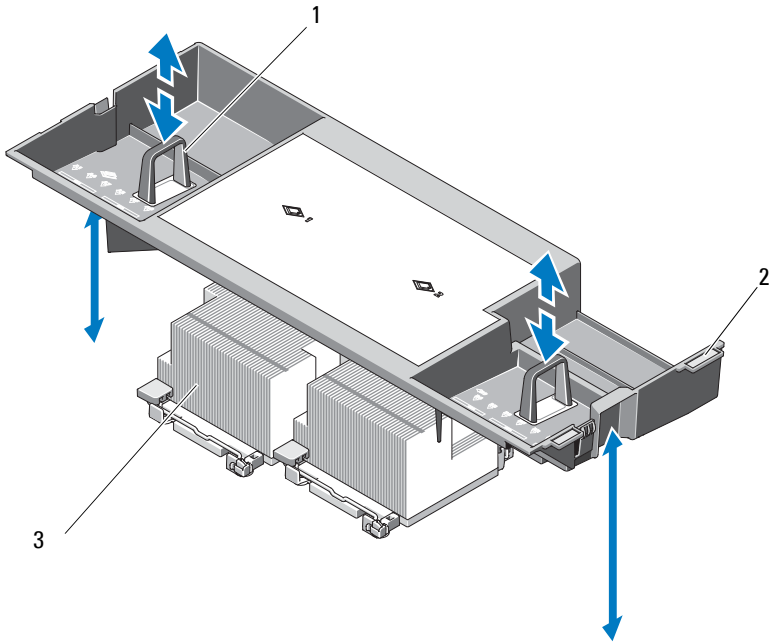
 **CAUTION:** Never operate your system with the cooling shroud removed. Overheating of the system can develop quickly resulting in a shutdown of the system and the loss of data.

## Removing the Cooling Shroud

 **CAUTION:** Many repairs may only be done by a certified service technician. You should only perform troubleshooting and simple repairs as authorized in your product documentation, or as directed by the online or telephone service and support team. Damage due to servicing that is not authorized by Dell is not covered by your warranty. Read and follow the safety instructions that came with the product.

- 1** Turn off the system, including any attached peripherals, and disconnect the system from the electrical outlet.
- 2** Open the system. See "Opening the System" on page 83.
- 3** Use the lift handles on the cooling shroud to lift the shroud out of the system. See Figure 3-12.

**Figure 3-12. Removing and Installing the Cooling Shroud**



- 1 lift handles
- 3 processor

- 2 alignment tabs

### Installing the Cooling Shroud

**CAUTION:** Many repairs may only be done by a certified service technician. You should only perform troubleshooting and simple repairs as authorized in your product documentation, or as directed by the online or telephone service and support team. Damage due to servicing that is not authorized by Dell is not covered by your warranty. Read and follow the safety instructions that came with the product.

- 1 Align the tabs on the right side of the cooling shroud with the cutouts in the right chassis wall.
- 2 Lower the right end of the shroud into the chassis cutouts and rotate the left end down inside the left chassis wall.



- 3 Close the system. See "Closing the System" on page 83.
- 4 Reconnect the system to the electrical outlet and turn on the system and attached peripherals.

## Cooling Fans

The system has either five or four hot-swappable fans to provide cooling to the system's interior components.



**NOTE:** In the event of a problem with a particular fan, the fan's number is referenced by the system's management software, allowing you to easily identify and replace the proper fan.

### Removing a Cooling Fan



**CAUTION:** Many repairs may only be done by a certified service technician. You should only perform troubleshooting and simple repairs as authorized in your product documentation, or as directed by the online or telephone service and support team. Damage due to servicing that is not authorized by Dell is not covered by your warranty. Read and follow the safety instructions that came with the product.



**CAUTION:** The cooling fans are hot-swappable. To maintain proper cooling while the system is on, replace only one fan at a time.



**CAUTION:** The fan blank must be installed in the FAN5 bay to maintain proper cooling while the system is on.



**NOTE:** If a fan is installed in FAN5, the fan will still be operational, however the fan will not appear in the iDRAC user interface unless the fan was installed before the system was started.

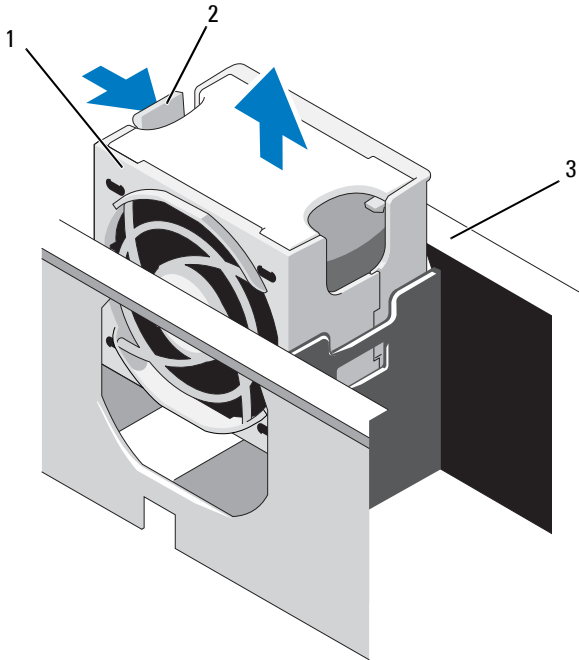
- 1 Open the system. See "Opening the System" on page 83.



**WARNING:** Use caution when handling the fan until the fan blades stop spinning.

- 2 Press the release tab while grasping the ends of the fan and lift the fan straight up from the fan bracket. See Figure 3-13.

**Figure 3-13. Removing and Installing a Cooling Fan**



1 fan

2 fan release handle

3 fan bracket

## Replacing a Cooling Fan



**CAUTION:** Many repairs may only be done by a certified service technician. You should only perform troubleshooting and simple repairs as authorized in your product documentation, or as directed by the online or telephone service and support team. Damage due to servicing that is not authorized by Dell is not covered by your warranty. Read and follow the safety instructions that came with the product.

- 1 Align the fan plug with the connector at the base of the fan bracket and lower the fan into the bracket until the fan is fully seated. See Figure 3-13.
- 2 Close the system. See "Closing the System" on page 83.

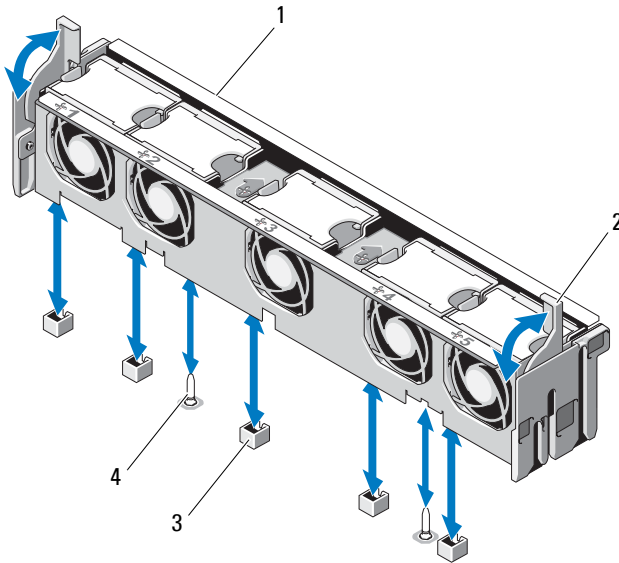
## Removing the Fan Bracket



**CAUTION: Many repairs may only be done by a certified service technician. You should only perform troubleshooting and simple repairs as authorized in your product documentation, or as directed by the online or telephone service and support team. Damage due to servicing that is not authorized by Dell is not covered by your warranty. Read and follow the safety instructions that came with the product.**

- 1 Turn off the system, including any attached peripherals, and disconnect the system from the electrical outlet.
- 2 Open the system. See "Opening the System" on page 83.
- 3 Optional: Remove the fans from the fan bracket. See "Removing a Cooling Fan" on page 105.
- 4 Lift the release latches on each end of the fan bracket and lift the bracket out of the system. See Figure 3-14.

**Figure 3-14. Removing and Installing the Processor Fan Bracket**



- |   |                               |   |               |
|---|-------------------------------|---|---------------|
| 1 | fan bracket                   | 2 | release latch |
| 3 | fan connector on system board | 4 | mounting pin  |


### Replacing the Fan Bracket

**CAUTION:** Many repairs may only be done by a certified service technician. You should only perform troubleshooting and simple repairs as authorized in your product documentation, or as directed by the online or telephone service and support team. Damage due to servicing that is not authorized by Dell is not covered by your warranty. Read and follow the safety instructions that came with the product.


- 1 Align the fan bracket down onto the bracket base so that the mounting pins fit correctly into the bracket base. See Figure 3-14.
- 2 Insert the bracket and engage the release levers to lock it in place.
- 3 If removed, replace the fans in the fan bracket. See "Replacing a Cooling Fan" on page 106.
- 4 Close the system. See "Closing the System" on page 83.

# Optical Drive

An optional slimline DVD-ROM or DVD+RW optical drive slides into the front panel and connects to the SATA controller on the system board. The optical drive is on the right or left side of the system, depending on your chassis.


 **NOTE:** DVD devices are data only.

## Removing the Optical Drive

 **CAUTION:** Many repairs may only be done by a certified service technician. You should only perform troubleshooting and simple repairs as authorized in your product documentation, or as directed by the online or telephone service and support team. Damage due to servicing that is not authorized by Dell is not covered by your warranty. Read and follow the safety instructions that came with the product.

- 1 Turn off the system, including any attached peripherals, and disconnect the system from its electrical outlet.
- 2 Open the system. See "Opening the System" on page 83.
- 3 Disconnect the optical drive cable from the back of the optical drive.
- 4 To remove the optical drive, press down on the blue release tab at the back of the optical drive and push the drive out of the system. See Figure 3-15.

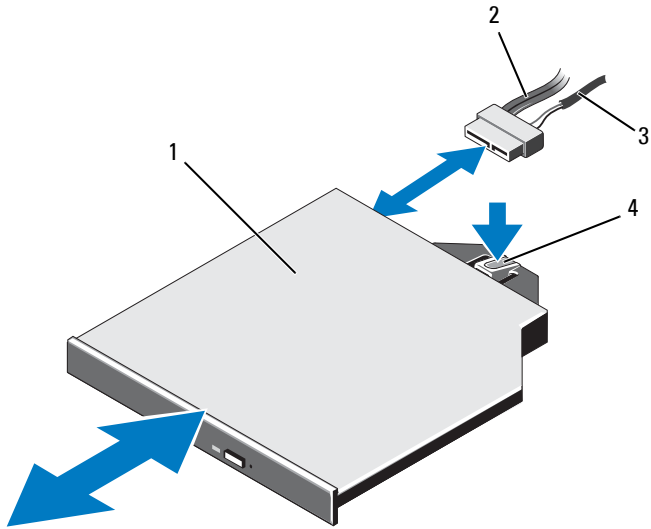
## Installing the Optical Drive

 **CAUTION:** Many repairs may only be done by a certified service technician. You should only perform troubleshooting and simple repairs as authorized in your product documentation, or as directed by the online or telephone service and support team. Damage due to servicing that is not authorized by Dell is not covered by your warranty. Read and follow the safety instructions that came with the product.

- 1 Turn off the system, including any attached peripherals, and disconnect the system from its electrical outlet.
- 2 Open the system. See "Opening the System" on page 83.
- 3 To remove the optical drive blank, press down on the blue release tab at the back of the blank and push the blank out of the system.
- 4 Align the optical drive with its opening in the front panel. See Figure 3-15.
- 5 Slide in the optical drive until the latch snaps into place.

- 6** Connect the optical drive cable to the back of the drive tray.
- 7** If not already done, connect the power and interface cables from the optical drive to the system board connectors.
  - a** Connect the power cable to the DVD/TBU\_PWR connector on the front of the system board below the fan bracket. See Figure 6-2 for the location of the connector.
  - b** Route the interface cable along the inside right wall of the chassis. See "Cable Routing" on page 118 and Figure 3-16.
  - c** Connect the cable to the SATA\_A connector on the system board. See Figure 6-2 for the location of the connector.
- 8** Close the system. See "Closing the System" on page 83.
- 9** Replace the bezel. See "Installing the Front Bezel" on page 82.
- 10** Reconnect your system and peripherals to their electrical outlets, and turn on the system.

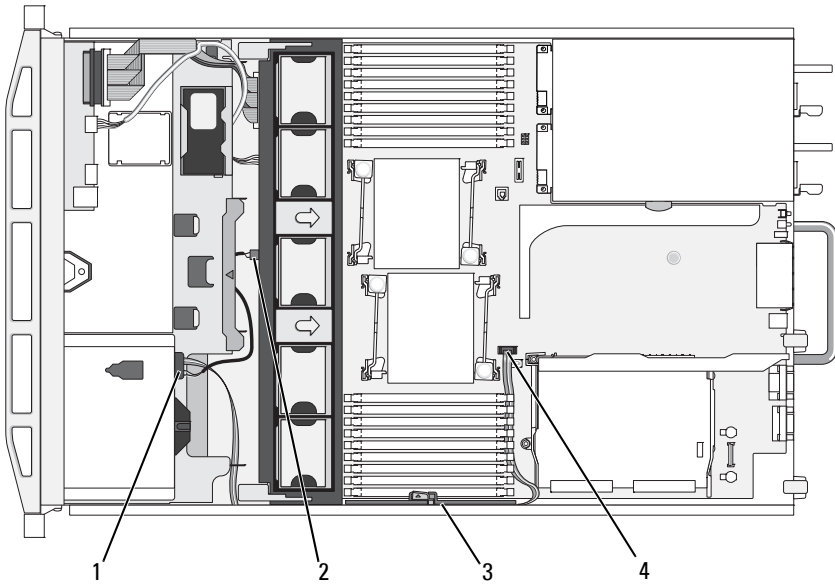
**Figure 3-15. Removing and Installing the Optical Drive**



- 1 optical drive
- 3 power cable

- 2 optical-drive interface cable
- 4 optical-drive release tab

**Figure 3-16. Routing the Optical Drive Cable**



- |   |                         |   |                       |
|---|-------------------------|---|-----------------------|
| 1 | optical drive connector | 2 | DVD/TBU_PWR connector |
| 3 | cable retention bracket | 4 | SATA_A connector      |

## **Integrated Storage Controller Card**

Your system includes a dedicated expansion-card slot on riser 1 for an integrated storage controller card that provides the storage subsystem for your system's internal hard drives. The controller supports SAS and SATA hard drives and also enables you to set up the hard drives in RAID configurations as supported by the version of the storage controller included with your system.



## Removing the Integrated Storage Controller Card

**△ CAUTION: Many repairs may only be done by a certified service technician. You should only perform troubleshooting and simple repairs as authorized in your product documentation, or as directed by the online or telephone service and support team. Damage due to servicing that is not authorized by Dell is not covered by your warranty. Read and follow the safety instructions that came with the product.**

- 1 Turn off the system, including any attached peripherals, and disconnect the system from the electrical outlet.
- 2 Open the system. See "Opening the System" on page 83.
- 3 Remove all expansion cards from expansion-card riser 1. See "Removing an Expansion Card" on page 123.
- 4 Disconnect the SAS cable(s) from the storage controller card.

**△ CAUTION: Disconnecting the RAID battery cable from a PERC card can cause data loss if the dirty cache LED on the card is lit. The LED indicates that data is still cached in controller memory and the data was not cleared at system shutdown.**

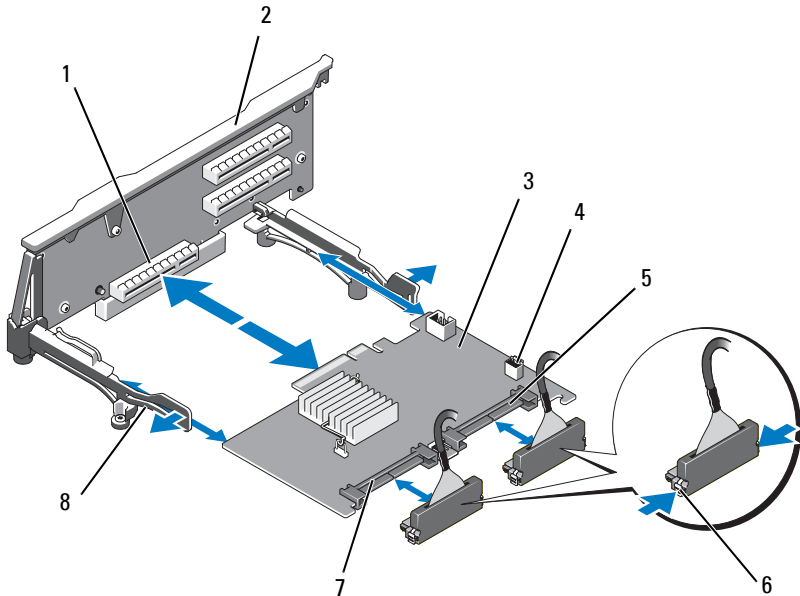
- 5 If necessary, disconnect the RAID battery cable from the controller.
- 6 Bend both card-edge guides outward and pull the storage controller card out of the connector. See Figure 3-17.
- 7 Bend outward on both card-edge guides to release the controller, lift the side of the controller that is adjacent to the blue guide, and then remove the controller out towards the rear of the chassis. See Figure 3-17.

## Installing the Integrated Storage Controller Card

**△ CAUTION: Many repairs may only be done by a certified service technician. You should only perform troubleshooting and simple repairs as authorized in your product documentation, or as directed by the online or telephone service and support team. Damage due to servicing that is not authorized by Dell is not covered by your warranty. Read and follow the safety instructions that came with the product.**

- 1 With the storage controller card-edge facing the riser, insert one side of the card into the black card-edge guide.
- 2 Bend outward on the blue card-edge guide, lower the card onto the blue card-edge guide, and release the guide. See Figure 3-17.

**Figure 3-17. Installing a Storage Controller Card**



- |   |   |   |                                    |
|---|---|---|------------------------------------|
| 1 | dedicated storage controller card connector | 2 | riser 1                            |
| 3 | integrated storage controller card          | 4 | RAID battery connector (PERC only) |
| 5 | SAS_1 connector                             | 6 | connector locking tabs             |
| 7 | SAS_0 connector                             | 8 | card edge guides (2)               |

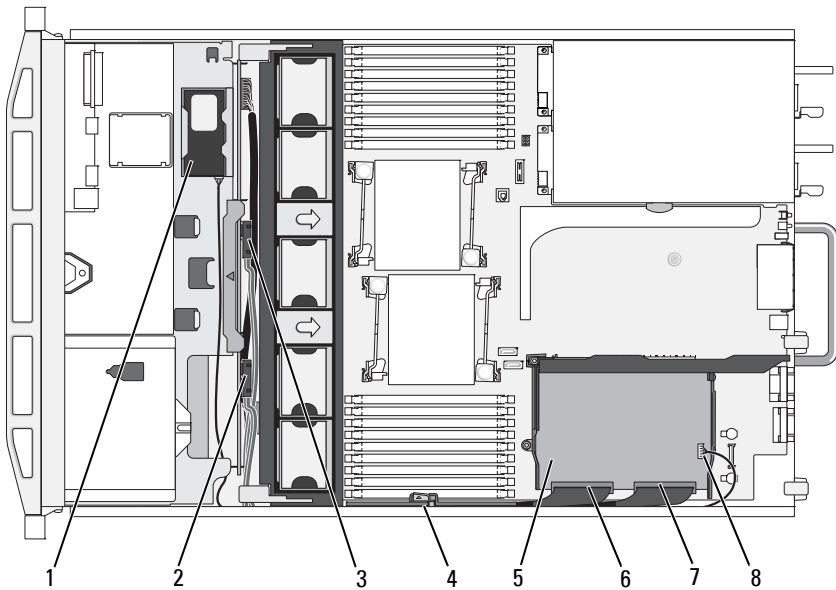
- 3 Slide the storage controller's card edge connector into the card slot on the riser until the card is fully seated. See Figure 3-17.
- 4 Connect the SAS\_0 cable to the storage controller's SAS\_0 connector, and connect the SAS\_1 cable to the controller's SAS\_1 connector.

**NOTE:** Be sure to connect the cable according to the connector labels on the cable. The cables are not operational if reversed.

- 5 For a battery-cached PERC controller, install the RAID battery. See "Installing a RAID Battery" on page 116.

- 6 If not already done, route the interface and RAID battery cables in the cable path inside the right interior wall of the chassis beneath the cable retention bracket. See "Cable Routing" on page 118 and Figure 3-18.
- 7 Connect the SAS A cable to the SAS A connector on the backplane and, if applicable, connect the SAS B cable to the SAS B connector on the backplane.
- 8 Close the system. See "Closing the System" on page 83.
- 9 Reconnect your system and peripherals to their electrical outlets, and turn on the system.

**Figure 3-18. Storage Controller Card Cabling**



- |   |                                    |   |                                    |
|---|------------------------------------|---|------------------------------------|
| 1 | RAID battery (PERC only)           | 2 | SAS B connector on backplane       |
| 3 | SAS A connector on backplane       | 4 | cable retention bracket            |
| 5 | integrated storage controller card | 6 | SAS_0 connector                    |
| 7 | SAS_1 connector                    | 8 | RAID battery connector (PERC only) |

# RAID Battery

The information in this section applies only to systems with the optional PERC controller card.

## Removing a RAID Battery

**△ CAUTION: Many repairs may only be done by a certified service technician. You should only perform troubleshooting and simple repairs as authorized in your product documentation, or as directed by the online or telephone service and support team. Damage due to servicing that is not authorized by Dell is not covered by your warranty. Read and follow the safety instructions that came with the product.**

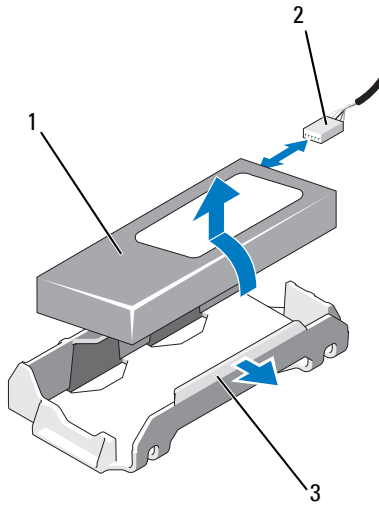
- 1 Pull back gently on the right edge of the battery bay and draw out the RAID battery from the battery carrier.
- 2 Disconnect the cable between the RAID battery and the storage controller card. See Figure 3-19.

## Installing a RAID Battery

**△ CAUTION: Many repairs may only be done by a certified service technician. You should only perform troubleshooting and simple repairs as authorized in your product documentation, or as directed by the online or telephone service and support team. Damage due to servicing that is not authorized by Dell is not covered by your warranty. Read and follow the safety instructions that came with the product.**

- 1 Connect the battery cable to the connector on the battery.
- 2 Locate the battery bay on top of the hard drive bays. See Figure 3-1.
- 3 With the cable oriented toward the back, angle the left side of the RAID battery into the left side of the battery bay. See Figure 3-19.
- 4 Rotate the right side of the battery down and press into the locked position.
- 5 If not already done, route the battery cable through the right chassis wall. See "Cable Routing" on page 118.
- 6 Connect the battery cable to the battery connector on the storage controller. See Figure 3-17.

**Figure 3-19. Removing or Installing a RAID Battery**




- 1 RAID battery
- 3 battery bay

- 2 RAID battery cable from storage controller

## Cable Routing

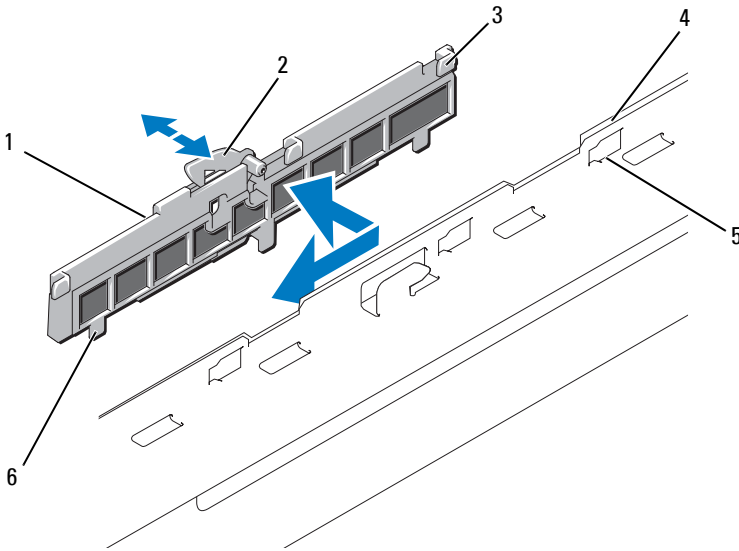
Cables that extend through the system front-to-back are routed along a cable path within the interior right wall of the system chassis. The cables are secured by a cable retention bracket that attaches to the inner wall.

### Removing the Cable Retention Bracket

 **CAUTION: Many repairs may only be done by a certified service technician. You should only perform troubleshooting and simple repairs as authorized in your product documentation, or as directed by the online or telephone service and support team. Damage due to servicing that is not authorized by Dell is not covered by your warranty. Read and follow the safety instructions that came with the product.**

- 1 Remove the cooling shroud. See "Removing the Cooling Shroud" on page 103.
- 2 Remove the cooling fan bracket. See "Removing the Fan Bracket" on page 107.
- 3 Press outward on the blue release latch on the cable retention bracket and slide the bracket back until the tabs at the bottom of the bracket clear the chassis. See Figure 3-20.
- 4 Lift the cable retention bracket off the chassis wall.

**Figure 3-20. Removing and Installing the Cable Retention Bracket**



- |   |                         |   |                    |
|---|-------------------------|---|--------------------|
| 1 | cable retention bracket | 2 | release latch      |
| 3 | hooks (3)               | 4 | right chassis wall |
| 5 | chassis slots (6)       | 6 | tab (3)            |

### Installing the Cable Retention Bracket



**CAUTION:** Many repairs may only be done by a certified service technician. You should only perform troubleshooting and simple repairs as authorized in your product documentation, or as directed by the online or telephone service and support team. Damage due to servicing that is not authorized by Dell is not covered by your warranty. Read and follow the safety instructions that came with the product.

- 1 Insert the hooks and tabs of the cable retention bracket into the slots in the chassis wall and slide the bracket back until the latch engages.
- 2 Install the cooling fan bracket. See "Replacing the Fan Bracket" on page 108.
- 3 Install the cooling shroud. See "Installing the Cooling Shroud" on page 104.

## Expansion Cards and Expansion-Card Risers

The system supports up to four PCI Express (PCIe) expansion cards on two expansion-card risers.

- Expansion-card riser 1 provides two PCIe x4-link Gen 2 expansion slots.
- Expansion-card riser 2 is offered in two versions:
  - The standard expansion-card riser 2 provides two PCIe x8-link Gen 2 expansion slots.
  - The optional expansion-card riser 2 provides one PCIe x16-link Gen 2 expansion slot.



**CAUTION: Expansion cards can only be plugged into the slots on the expansion-card risers. Do not plug any expansion cards into the riser connectors on the system board.**


To identify expansion slots, see "Expansion-Card Riser-Board Components and PCIe Buses" on page 184.

### Expansion Card Installation Guidelines

Observe the following notes and guidelines regarding the expansion-card slots:

- PCI Express Generation 2 and Generation 1 expansion cards are supported in all slots.
- In slots 2, 3, and 4, expansion cards can have a maximum length of 24.13 cm (9.5"). Slot 1 supports a full-length (30.99-cm [12.2"]) expansion card.
- The system supports three full-height expansion cards and one low-profile expansion card (slot 2).
- Although slots 1 and 2 are physically PCIe x8 connectors, they function only as PCIe x4-link slots.
- When the optional x16-link riser is installed, slot 4 is not available.
- The expansion-card slots are not hot-swappable.
- Besides the integrated storage controller, the system supports a maximum of two PERC controller expansion cards to manage external storage.



 **CAUTION:** To ensure proper cooling no more than two of the four expansion cards can have a power consumption of greater than 15W (up to 25W maximum each), not including the integrated storage controller.

- Table 3-1 provides a guide for installing expansion cards to ensure proper cooling and mechanical fit. The expansion cards with the highest priority should be installed first using the slot priority indicated. All other expansion cards should be installed in card priority and slot priority order.


**Table 3-1. Expansion-Card Installation Order**


Card Priority	Card Type	Slot Priority	Max Allowed	Greater Than 15W?
1	PERC 5/E controller	1,3,4	2	Y
2	PERC 6/E controller	3,4,1	2	Y
3	10 Gb NIC	3,4,1,2	2	Y
4	All other Dell storage cards	3,4,1	2	Y
5	All other NICs	1,2,3,4	4 <sup>1</sup>	N <sup>2</sup>
6	Non-Dell storage cards	1,2,3,4	4 <sup>1</sup>	N <sup>2</sup>


<sup>1</sup> Maximum of 2 of any card whose maximum power exceeds 15W.


<sup>2</sup> Refer to the expansion card documentation to ensure that the maximum power does not exceed 15W.

## Installing an Expansion Card

 **CAUTION:** Many repairs may only be done by a certified service technician. You should only perform troubleshooting and simple repairs as authorized in your product documentation, or as directed by the online or telephone service and support team. Damage due to servicing that is not authorized by Dell is not covered by your warranty. Read and follow the safety instructions that came with the product.

 **NOTE:** Before installing any expansion cards, see "Expansion Card Installation Guidelines" on page 120.


 **NOTE:** The procedure for installing expansion cards into risers 1 and 2 is the same except that slots 3 and 4 on riser 2 have card-edge guides for installing 24.13-cm (9.5") expansion cards.

- 1** Unpack the expansion card and prepare it for installation.  
For instructions, see the documentation accompanying the card.
- 2** Turn off the system, including any attached peripherals, and disconnect the system from the electrical outlet.
- 3** Open the system. See "Opening the System" on page 83.
- 4** Open the expansion-card guide latch and remove the filler bracket at the back of the system. See Figure 3-21.  
 **NOTE:** Keep this bracket in case you need to remove the expansion card. Filler brackets must be installed over empty expansion-card slots to maintain FCC certification of the system. The brackets also keep dust and dirt out of the system and aid in proper cooling and airflow inside the system.
- 5** Install the expansion card:
  - a** If the expansion card is 24.13 cm (9.5 in), align its front edge with the front card guide. See Figure 3-21.
  - b** Position the expansion card so that the card-edge connector aligns with the expansion-card connector on the expansion-card riser board.
  - c** Insert the card-edge connector firmly into the PCIe card connector until the card is fully seated.
  - d** When the card is seated in the connector, close the expansion-card latch. See Figure 3-21.
- 6** Connect any expansion-card cables for the new card.  
See the documentation that came with the card for information about its cable connections.
- 7** Close the system. See "Closing the System" on page 83.
- 8** Reconnect your system and peripherals to their electrical outlets, and turn on the system.

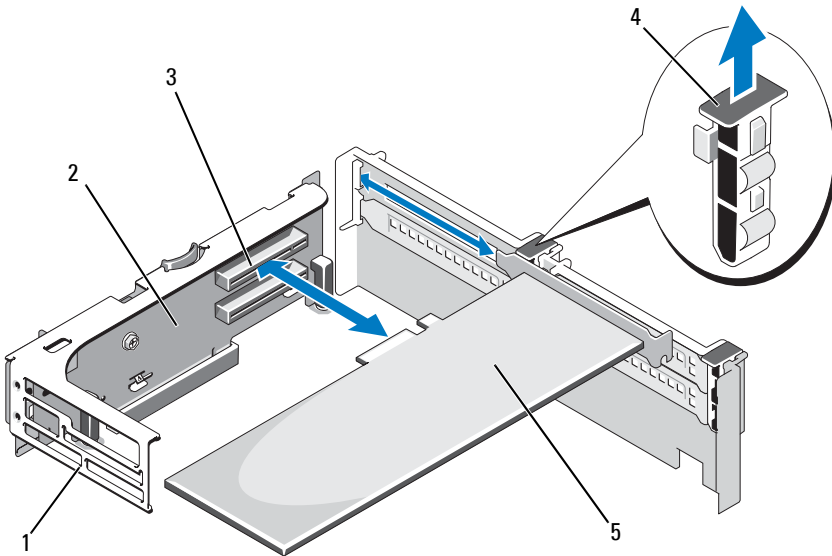
## Removing an Expansion Card



**CAUTION:** Many repairs may only be done by a certified service technician. You should only perform troubleshooting and simple repairs as authorized in your product documentation, or as directed by the online or telephone service and support team. Damage due to servicing that is not authorized by Dell is not covered by your warranty. Read and follow the safety instructions that came with the product.

- 1 Turn off the system, including any attached peripherals, and disconnect the system from the electrical outlet.
- 2 Open the system. See "Opening the System" on page 83.
- 3 Disconnect any cables connected to the expansion card.
- 4 Remove the expansion card:
  - a Open the expansion-card latch at the back of the system chassis. See Figure 3-21.
  - b Grasp the expansion card by its top corners, and carefully pull the card from the expansion-card connector.
- 5 If you are removing the card permanently, install a metal filler bracket over the empty expansion slot opening and close the expansion-card latch.  
 **NOTE:** You must install a filler bracket over an empty expansion slot to maintain Federal Communications Commission (FCC) certification of the system. The brackets also aid in proper cooling and airflow inside the system.
- 6 Close the system. See "Closing the System" on page 83.
- 7 Reconnect your system and peripherals to their electrical outlets, and turn on the system.

**Figure 3-21. Removing or Installing an Expansion Card**



- |   |                          |   |                            |
|---|--------------------------|---|----------------------------|
| 1 | front card guide         | 2 | expansion-card riser 2     |
| 3 | expansion-card connector | 4 | expansion-card guide latch |
| 5 | expansion card           |   |                            |

### Removing Expansion-Card Riser 1

**CAUTION:** Many repairs may only be done by a certified service technician. You should only perform troubleshooting and simple repairs as authorized in your product documentation, or as directed by the online or telephone service and support team. Damage due to servicing that is not authorized by Dell is not covered by your warranty. Read and follow the safety instructions that came with the product.

**NOTE:** You must remove all expansion cards from the expansion-card riser before removing the riser from the system.

**NOTE:** The system will not start with a riser board removed.

- 1 Turn off the system, including any attached peripherals, and disconnect the system from the electrical outlet.
- 2 Open the system. See "Opening the System" on page 83.
- 3 Disconnect all cables connected to the expansion card.
- 4 Remove all expansion cards from the expansion-card riser. See "Removing an Expansion Card" on page 123.
- 5 Press the tab at the bottom of the riser to release the board from the card slot and lift expansion-card riser 1 off of the mounting pins and out of the system. See Figure 3-22.

## Replacing Expansion-Card Riser 1



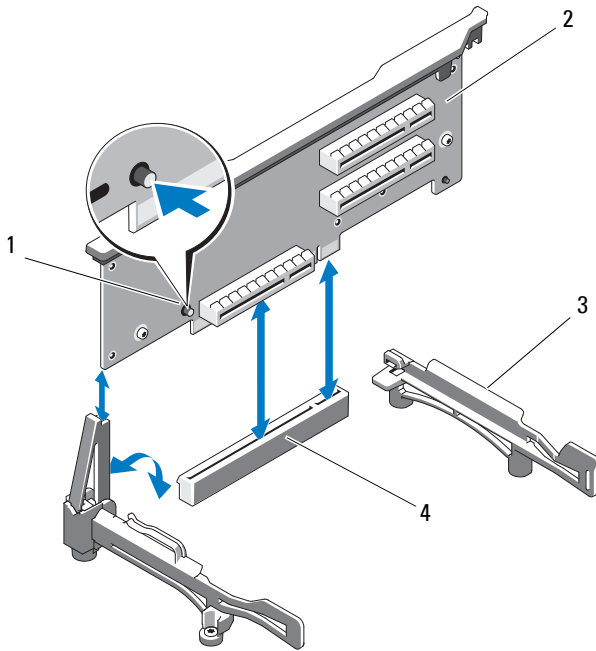
**CAUTION:** Many repairs may only be done by a certified service technician. You should only perform troubleshooting and simple repairs as authorized in your product documentation, or as directed by the online or telephone service and support team. Damage due to servicing that is not authorized by Dell is not covered by your warranty. Read and follow the safety instructions that came with the product.



**NOTE:** The system will not start with a riser board removed.

- 1 Aligning the pin collar over the mounting pin on the system board, lower expansion-card riser 1 until the board connector is firmly seated into the system board socket. See Figure 3-22.
- 2 Reinstall any expansion cards. See "Installing an Expansion Card" on page 121.
- 3 Reconnect all expansion-card cables.
- 4 Close the system. See "Closing the System" on page 83.
- 5 Reconnect your system and peripherals to their electrical outlets, and turn on the system.

**Figure 3-22. Removing and Replacing Expansion-Card Riser 1**



- |   |                  |   |                        |
|---|------------------|---|------------------------|
| 1 | release button   | 2 | expansion-card riser 1 |
| 3 | card edge guides | 4 | system board socket    |

### Removing Expansion-Card Riser 2

**CAUTION:** Many repairs may only be done by a certified service technician. You should only perform troubleshooting and simple repairs as authorized in your product documentation, or as directed by the online or telephone service and support team. Damage due to servicing that is not authorized by Dell is not covered by your warranty. Read and follow the safety instructions that came with the product.

**NOTE:** You must remove all expansion cards from the expansion-card riser before removing the riser from the system.

**NOTE:** The system will not start with an expansion-card riser removed.

- 1 Turn off the system, including any attached peripherals, and disconnect the system from the electrical outlet.
- 2 Open the system. See "Opening the System" on page 83.
- 3 Disconnect all cables connected to the expansion card.
- 4 Remove any expansion cards from the expansion-card riser. See "Removing an Expansion Card" on page 123.
- 5 Press the blue release latch on expansion-card riser 2 and lift the riser straight up to clear the chassis. See Figure 3-23.

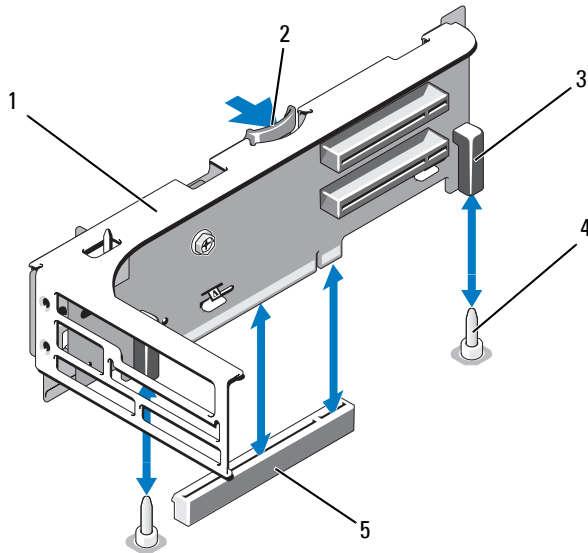
## Replacing Expansion-Card Riser 2



**CAUTION: Many repairs may only be done by a certified service technician. You should only perform troubleshooting and simple repairs as authorized in your product documentation, or as directed by the online or telephone service and support team. Damage due to servicing that is not authorized by Dell is not covered by your warranty. Read and follow the safety instructions that came with the product.**

- 1 Align the guides on each end of expansion-card riser 2 with the mounting pins on the system board, and lower the riser into the system until the latches on the riser engage. See Figure 3-23.
- 2 Reinstall any expansion cards. See "Installing an Expansion Card" on page 121.
- 3 Reconnect all expansion-card cables.
- 4 Close the system. See "Closing the System" on page 83.
- 5 Reconnect your system and peripherals to their electrical outlets, and turn on the system.

**Figure 3-23. Removing and Replacing Expansion-Card Riser 2**



- |   |                                   |   |                   |
|---|-----------------------------------|---|-------------------|
| 1 | expansion-card riser 2            | 2 | release latch     |
| 3 | pin collars (2)                   | 4 | mounting pins (2) |
| 5 | riser 2 connector on system board |   |                   |

### **Removing Expansion-Card Riser 2 From the Expansion-Card Bracket**

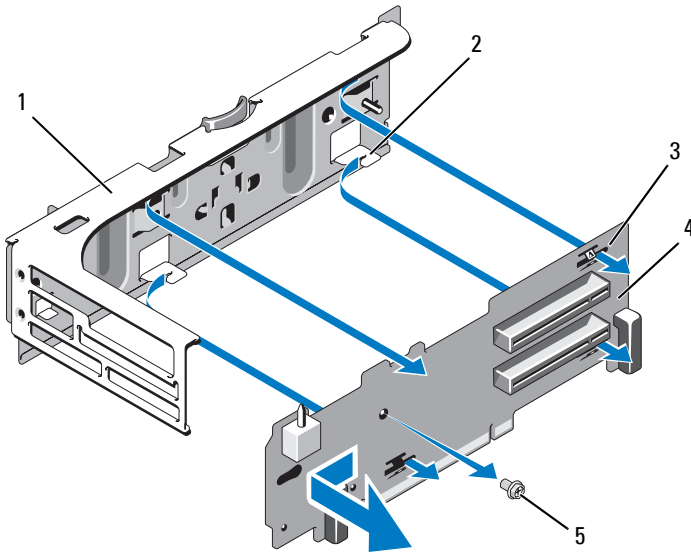
**△ CAUTION:** Many repairs may only be done by a certified service technician. You should only perform troubleshooting and simple repairs as authorized in your product documentation, or as directed by the online or telephone service and support team. Damage due to servicing that is not authorized by Dell is not covered by your warranty. Read and follow the safety instructions that came with the product.

- 1 Turn off the system and attached peripherals, and disconnect the system from the electrical outlet.
- 2 Open the system. See "Opening the System" on page 83.
- 3 Remove any expansion cards from the expansion-card riser 2. See "Removing an Expansion Card" on page 123.



- 4 Remove expansion-card riser 2. See "Removing Expansion-Card Riser 2" on page 126.

**Figure 3-24. Removing and Replacing the Riser 2 Board**



- |   |                        |   |               |
|---|------------------------|---|---------------|
| 1 | expansion-card bracket | 2 | tab hook (4)  |
| 3 | tab slot (4)           | 4 | riser 2 board |
| 5 | screw                  |   |               |

- 5 Remove the expansion-card riser board:
  - a Using a Phillips screwdriver, remove the securing screw from the assembly. See Figure 3-24.
  - b Slide the riser board off of the four securing tab hooks.
  - c Lift the riser board from the bracket.

## Replacing the Riser 2 Board on the Expansion-Card Bracket



**CAUTION: Many repairs may only be done by a certified service technician. You should only perform troubleshooting and simple repairs as authorized in your product documentation, or as directed by the online or telephone service and support team. Damage due to servicing that is not authorized by Dell is not covered by your warranty. Read and follow the safety instructions that came with the product.**

- 1 Place the riser board in the expansion-card bracket so that the four tab hooks are fully inserted through the tab slots on the riser board. See Figure 3-24.
- 2 Slide the riser board into the tab hooks.
- 3 Using a Phillips screwdriver, secure the board with the Phillips screw.
- 4 Reinstall expansion-card riser 2. See "Replacing Expansion-Card Riser 2" on page 127.
- 5 Install all expansion cards in the expansion-card slots. See "Installing an Expansion Card" on page 121.
- 6 Close the system. See "Closing the System" on page 83.
- 7 Reconnect your system and peripherals to their electrical outlets, and turn on the system.

## System Memory

Your system supports DDR3 registered DIMMs (RDIMMs) or ECC unbuffered DIMMs (UDIMMs). Single and dual-rank DIMMs can be 1067- or 1333-MHz, and quad-rank DIMMs can be 1067-MHz.

The system contains 18 memory sockets split into two sets of nine sockets, one set for each processor. Each nine-socket set is organized into three channels of three memory sockets per channel. The first socket of each channel is marked with white release levers.

The maximum memory that is supported on your system varies according to the types and sizes of memory modules being used:

- Single-rank and dual-rank RDIMMs of sizes 2-GB, 4-GB, and 8-GB (when available) are supported for a total of up to 144 GB.
- Quad-rank RDIMMs (two per channel) are supported for a total of up to 96 GB.
- 1-GB and 2-GB UDIMMs are supported for a total of up to 24 GB.

## General Memory Module Installation Guidelines

To ensure optimal performance of your system, observe the following general guidelines when configuring your system memory.



**NOTE:** Memory configurations that fail to observe these guidelines can cause your system to halt at startup without any video output of system messages.

- RDIMMs and UDIMMs cannot be mixed.
- No more than two UDIMMs can be populated per channel.
- Except for memory channels that are unused, all populated memory channels must have identical configurations.
- Memory modules of different sizes can be mixed within a memory channel (for example, 2-GB, 8-GB, and 4-GB), but all populated channels must have identical configurations.
- For Optimizer Mode, memory modules are installed in the numeric order of the sockets beginning with A1 or B1.
- For Memory Mirroring or Advanced ECC Mode, the three sockets furthest from the processor are unused and memory modules are installed beginning with socket A2 or B2 and proceeding in the numeric order of the remaining sockets (for example, A2, A3, A5, A6, A8, and A9).
- Advanced ECC Mode requires x4 or x8 DRAM device widths.
- The memory speed of each channel depends on the memory configuration:
  - For single or dual-rank memory modules:
    - One memory module per channel supports up to 1333 MHz.
    - Two memory modules per channel supports up to 1067 MHz.

- Three memory modules per channel are limited to 800 MHz, regardless of memory module speed.
- For quad-rank memory modules:
  - One memory module per channel supports up to 1067 MHz.
  - Two memory modules per channel are limited to 800 MHz, regardless of memory module speed.
- If a quad-rank memory module is installed, then only one other memory module can be added to that channel.
- If quad-rank memory modules are mixed with single- or dual-rank modules, the quad-rank modules must be installed in the sockets with the white release levers.
- If memory modules with different speeds are installed, they will operate at the speed of the slowest installed memory module(s).

## Mode-Specific Guidelines

The number of channels and allowable configurations depend on the memory mode selected.

### Advanced ECC (Lockstep) Mode Support

In this configuration, the two channels closest to the processor are combined to form one 128-bit channel. This mode supports SDDC for both x4- and x8-based memory modules. Memory modules must be identical in size, speed, and technology in corresponding slots.

### Memory Mirroring Support

The system supports memory mirroring if identical memory modules are installed in the two channels closest to the processor (memory is not installed in the farthest channel). Mirroring must be enabled in the System Setup program. In a mirrored configuration, the total available system memory is one-half of the total installed physical memory.

### Optimizer (Independent Channel) Mode

In this mode, all three channels are populated with identical memory modules. This mode permits a larger total memory capacity but does not support SDDC with x8-based memory modules.

A minimal single-channel configuration of one 1-GB memory module is also supported in this mode.

Table 3-2 and Table 3-3 show sample memory configurations that follow the appropriate memory guidelines stated in this section. The samples show identical memory-module configurations and their physical and available memory totals. The tables do not show mixed or quad-rank memory-module configurations, nor do they address the memory speed considerations of any configuration.

**Table 3-2. Sample RDIMM Single- and Dual-Rank Memory Configurations**

Memory Mode	Memory Module Size	Memory Sockets			Physical Memory (GB)	Available Memory (GB)
		1 4 7	2 5 8	3 6 9		
Optimizer	2 GB	X			2	all
		X	X		4	
		X	X	X	6	
		X X			4	
		X X	X X		8	
		X X	X X	X X	12	
		X X X	X X X		12	
		X X X	X X X	X X X	18	
	4 GB	X			4	all
		X	X		8	
		X	X	X	12	
		X X			8	
		X X	X X		16	
		X X	X X	X X	24	
		X X X	X X X		24	
		X X X	X X X	X X X	36	
	8 GB <sup>1</sup>	X			8	all
		X	X		16	
		X	X	X	24	
		X X			16	
		X X	X X		32	
		X X	X X	X X	48	
		X X X	X X X		48	
		X X X	X X X	X X X	72	

**Table 3-2. Sample RDIMM Single- and Dual-Rank Memory Configurations (continued)**

Memory Mode	Memory Module Size	Memory Sockets						Physical Memory (GB)	Available Memory (GB)
		1 4 7	2 5 8	3 6 9					
Advanced ECC <sup>2</sup>	2 GB	vacant	X X X X X X	X X X X X X			4 8 12	all	
	4 GB	vacant	X X X X X X	X X X X X X			8 16 24	all	
	8 GB <sup>1</sup>	vacant	X X X X X X	X X X X X X			16 32 48	all	
Mirroring	2 GB	vacant	X X X X X X	X X X X X X			4 8 12	2 4 6	
	4 GB	vacant	X X X X X X	X X X X X X			8 16 24	4 8 12	
	8 GB <sup>1</sup>	vacant	X X X X X X	X X X X X X			16 32 48	8 16 24	

<sup>1</sup> When available

<sup>2</sup> Requires x4- or x8-based memory modules

**Table 3-3. Sample UDIMM Memory Configurations**

Memory Mode	Memory Module Size	Memory Sockets			Physical Memory (GB)	Available Memory (GB)	
		1 4 7	2 5 8	3 6 9			
Optimizer	1 GB	X			1	all	
		X	X		2		
		X	X	X	3		
	X X	X X		4			
	X X	X X	X X	6			
2 GB	2 GB	X			2	all	
		X	X		4		
		X	X	X	6		
	X X	X X		8			
	X X	X X	X X	12			
Advanced ECC <sup>1</sup>	1 GB	vacant	X	X	2	all	
			X X	X X	4		
	2 GB	vacant	X	X	4		all
			X X	X X	8		
Mirroring	1 GB	vacant	X	X	2	1 2	
			X X	X X	4		
	2 GB	vacant	X	X	4		2 4
			X X	X X	8		

<sup>1</sup> Requires x4- or x8-based memory modules

## Installing Memory Modules



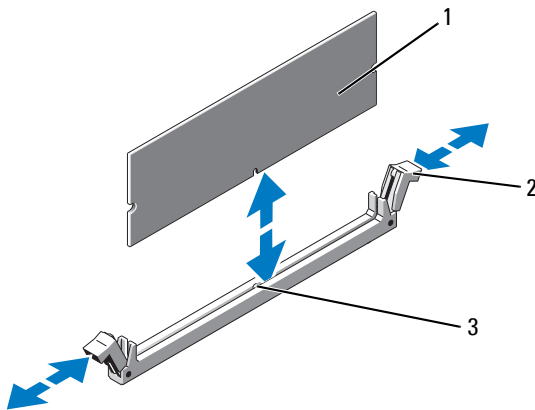
**CAUTION:** Many repairs may only be done by a certified service technician. You should only perform troubleshooting and simple repairs as authorized in your product documentation, or as directed by the online or telephone service and support team. Damage due to servicing that is not authorized by Dell is not covered by your warranty. Read and follow the safety instructions that came with the product.



**WARNING:** The memory modules are hot to the touch for some time after the system has been powered down. Allow time for the memory modules to cool before handling them. Handle the memory modules by the card edges and avoid touching the components on the memory module.

- 1 Turn off the system, including any attached peripherals, and disconnect the system from the electrical outlet.
- 2 Open the system. See "Opening the System" on page 83.
- 3 Remove the cooling shroud. See "Removing the Cooling Shroud" on page 103.
- 4 Locate the memory module sockets. See Figure 6-2.
- 5 Press outward on the memory module ejectors to allow the memory module to be inserted into the socket. See Figure 3-25.

**Figure 3-25. Installing and Removing a Memory Module**



- |   |               |   |                                   |
|---|---------------|---|-----------------------------------|
| 1 | memory module | 2 | memory module socket ejectors (2) |
| 3 | alignment key |   |                                   |

**CAUTION:** Handle each memory module only by the card edges, ensuring not to touch the components on the module.

- 6 Align the memory module's edge connector with the alignment key of the memory module socket, and insert the memory module in the socket.

**NOTE:** The memory module socket has an alignment key that allows you to install the memory module in the socket in only one way.

- 7 Press down on the memory module with your thumbs until the ejectors lock into position. See Figure 3-25.



When the memory module is properly seated in the socket, the ejectors on the memory module socket align with the ejectors on the other sockets that have memory modules installed.

- 8 Repeat step 5 through step 7 of this procedure to install the remaining memory modules. See Table 3-2 or Table 3-3.
- 9 Replace the cooling shroud. See "Installing the Cooling Shroud" on page 104.
- 10 Close the system. See "Closing the System" on page 83.
- 11 Reconnect your system and peripherals to their electrical outlets, and turn on the system.
- 12 Press <F2> to enter the System Setup program, and check the **System Memory** setting on the main System Setup screen.  
The system should have already changed the value to reflect the newly installed memory.
- 13 If the value is incorrect, one or more of the memory modules may not be installed properly. Repeat step 2 through step 12 of this procedure, checking to ensure that the memory modules are firmly seated in their sockets.
- 14 Run the system memory test in the system diagnostics. See "Running the System Diagnostics" on page 173.

## Removing Memory Modules




**CAUTION:** Many repairs may only be done by a certified service technician. You should only perform troubleshooting and simple repairs as authorized in your product documentation, or as directed by the online or telephone service and support team. Damage due to servicing that is not authorized by Dell is not covered by your warranty. Read and follow the safety instructions that came with the product.



**WARNING:** The memory modules are hot to the touch for some time after the system has been powered down. Allow time for the memory modules to cool before handling them. Handle the memory modules by the card edges and avoid touching the components on the memory module.

- 1 Turn off the system, including any attached peripherals, and disconnect the system from the electrical outlet.
- 2 Open the system. See "Opening the System" on page 83.


- 3 Remove the cooling shroud. See "Removing the Cooling Shroud" on page 103.
- 4 Locate the memory module sockets. See Figure 6-2.
- 5 Press down and out on the ejectors on each end of the socket until the memory module pops out of the socket. See Figure 3-25.

 **CAUTION: Handle each memory module only by the card edges, ensuring not to touch the components on the module.**


- 6 Reinstall the cooling shroud.
- 7 Close the system. See "Closing the System" on page 83.
- 8 Reconnect your system and peripherals to their electrical outlets, and turn on the system.

## Processors

### Removing a Processor

 **CAUTION: Many repairs may only be done by a certified service technician. You should only perform troubleshooting and simple repairs as authorized in your product documentation, or as directed by the online or telephone service and support team. Damage due to servicing that is not authorized by Dell is not covered by your warranty. Read and follow the safety instructions that came with the product.**

- 1 Prior to upgrading your system, download the latest system BIOS version from [support.dell.com](http://support.dell.com) and follow the instructions included in the compressed download file to install the update on your system.
- 2 Turn off the system, including any attached peripherals, and disconnect the system from the electrical outlet. When disconnected from AC power, press and hold the power button for 3 seconds to fully drain the system of stored power prior to removing the cover.

 **NOTE:** It is recommended that you always use a static mat and static strap while working on components in the interior of the system.

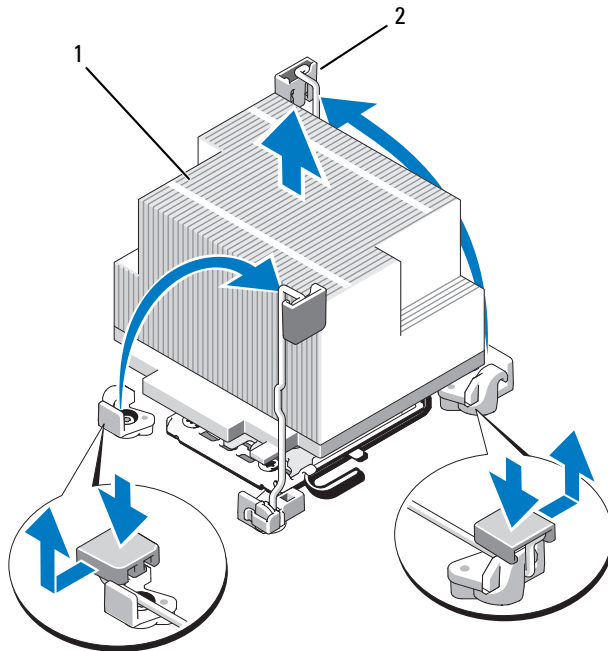
- 3 Open the system. See "Opening the System" on page 83.
- 4 Remove the cooling shroud. See "Removing the Cooling Shroud" on page 103.

**⚠ WARNING:** The heat sink and processor are hot to the touch for some time after the system has been powered down. Allow the heat sink and processor to cool before handling them.

**⚠ CAUTION:** Never remove the heat sink from a processor unless you intend to remove the processor. The heat sink is necessary to maintain proper thermal conditions.

- 5 Release one of the heat-sink release levers. See Figure 3-26.
- 6 Wait 30 seconds for the heat sink to loosen from the processor.
- 7 Release the other heat-sink release lever.
- 8 Gently lift the heat sink off of the processor and set the heat sink aside upside down (thermal grease side facing up).

**Figure 3-26. Installing and Removing the Heat Sink**



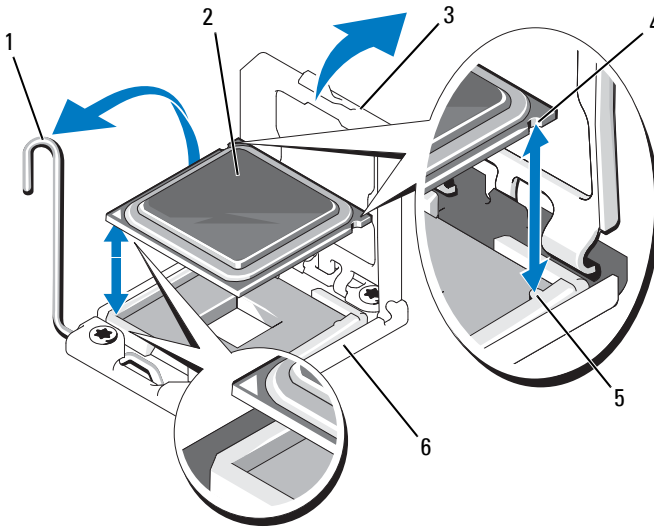
1 heat sink

2 release lever (2)

**CAUTION:** The processor is held in its socket under strong pressure. Be aware that the release lever can spring up suddenly if not firmly grasped.

- 9 Position your thumb firmly over the processor socket-release lever and release the lever from the locked position. Rotate the lever 90 degrees upward until the processor is released from the socket. See Figure 3-27.
- 10 Rotate the processor shield upward and out of the way. See Figure 3-27.

**Figure 3-27. Installing and Removing a Processor**




- |   |                      |   |                        |
|---|----------------------|---|------------------------|
| 1 | socket-release lever | 2 | processor              |
| 3 | processor shield     | 4 | notch in processor (2) |
| 5 | socket key (2)       | 6 | ZIF socket             |

**CAUTION:** Be careful not to bend any of the pins on the ZIF socket when removing the processor. Bending the pins can permanently damage the system board.


- 11 Lift the processor out of the socket and leave the release lever up so that the socket is ready for the new processor.


After removing the processor, place it in an antistatic container for reuse, return, or temporary storage.

 **NOTE:** Do not touch the bottom of the processor. Touch only the side edges of the processor.


If you are permanently removing the processor, you must install a processor blank and a heat-sink blank in the CPU2 socket to ensure proper system cooling. Adding the blanks is similar to installing a processor. See "Installing a Processor" on page 141.

## Installing a Processor

 **CAUTION:** Many repairs may only be done by a certified service technician. You should only perform troubleshooting and simple repairs as authorized in your product documentation, or as directed by the online or telephone service and support team. Damage due to servicing that is not authorized by Dell is not covered by your warranty. Read and follow the safety instructions that came with the product.

 **NOTE:** CPU1 socket must be used.

- 1 Remove the heat-sink blank and the processor blank from the vacant processor socket. Removing the blanks is similar to removing a processor. See "Removing a Processor" on page 138.
- 2 Remove the processor from the packing material by the processor's edges only. Do not touch the bottom of the processor. Handle the processor carefully with your fingers on the side edges. Place your hand beneath the processor when you are moving it to the system.
- 3 Locate the pin 1 indicator on the system board socket.
- 4 Locate the pin 1 indicator on the top of the processor. The pin 1 indicator is shown as a triangle on the top of the processor. See Figure 3-27.

 **CAUTION:** Positioning the processor incorrectly can permanently damage the system board or the processor. Be careful not to bend the pins in the socket.

- 5 Place the processor over the socket with each pin 1 aligned and level. See Figure 3-27.

 **CAUTION:** Do not use force to seat the processor. When the processor is positioned correctly, it engages easily into the socket.

- 6 Align the notches in the processor with the socket keys on the ZIF socket. See Figure 3-27.
- 7 Install the processor in the socket. Keep the processor level (See Figure 3-27) and insert it straight down into the socket. Allow the processor to float on the pins, allowing the processor shield to hold it in place.
- 8 Verify that the processor is properly aligned and seated.
- 9 Close the processor shield. See Figure 3-27.
- 10 Rotate the socket-release lever down until it snaps into place. See Figure 3-27.
- 11 Install the heat sink.



**NOTE:** Your kit may contain a replacement heat sink if you are installing a processor that consumes additional power. The new heat sink may not appear different than the original one; however, it has improved thermal dissipation specifications and must be used.

- a Using a clean lint-free cloth, remove the thermal grease from the heat sink.



**CAUTION:** Applying too much thermal grease can result in excess grease coming in contact with and contaminating the processor socket.

- b Open the grease applicator included with your processor kit and apply all of the thermal grease in the applicator to the center of the top side of the new processor.
  - c Place the heat sink on the processor. See Figure 3-26.
  - d Close the heat-sink release levers or replace the screws at the corners of the heat sink. See Figure 3-26.
- 12 Replace the cooling shroud. See "Installing the Cooling Shroud" on page 104.
  - 13 Close the system. See "Closing the System" on page 83.
  - 14 Reconnect your system and peripherals to their electrical outlets, and turn on the system.
  - 15 Press <F2> to enter the System Setup program, and check that the processor information matches the new system configuration. See "Entering the System Setup Program" on page 58.

- 16 Run the system diagnostics to verify that the new processor operates correctly.
- 17 See "Running the System Diagnostics" on page 173 for information about running the diagnostics.

## System Battery

### Replacing the System Battery



**CAUTION:** Many repairs may only be done by a certified service technician. You should only perform troubleshooting and simple repairs as authorized in your product documentation, or as directed by the online or telephone service and support team. Damage due to servicing that is not authorized by Dell is not covered by your warranty. Read and follow the safety instructions that came with the product.



**WARNING:** There is a danger of a new battery exploding if it is incorrectly installed. Replace the battery only with the same or equivalent type recommended by the manufacturer. See your safety information for additional info.

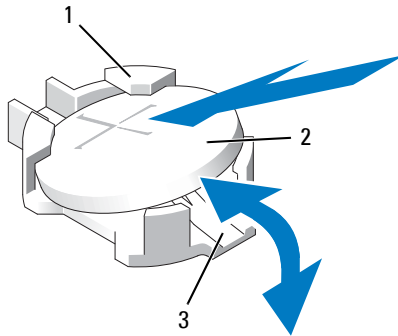
- 1 Turn off the system, including any attached peripherals, and disconnect the system from the electrical outlet.
- 2 Open the system. See "Opening the System" on page 83.
- 3 Remove the fan bracket. See "Removing the Fan Bracket" on page 107.
- 4 Locate the battery socket. See "System Board Connectors" on page 180.



**CAUTION:** To avoid damage to the battery connector, you must firmly support the connector while installing or removing a battery.

- 5 To remove the battery, support the battery connector by pressing down firmly on the positive side of the connector.
- 6 Lift the battery out of the securing tabs at the negative side of the connector.

**Figure 3-28. Replacing the System Battery**



- 1 positive side of battery connector      2 system battery
- 3 negative side of battery connector

- 7 To install a new system battery, support the battery connector by pressing down firmly on the positive side of the connector.
- 8 Hold the battery with the “+” facing up and slide it under the securing tabs at the positive side of the connector.
- 9 Press the battery straight down into the connector until it snaps into place.
- 10 Replace the fan bracket. See "Replacing the Fan Bracket" on page 108.
- 11 Close the system. See "Closing the System" on page 83.
- 12 Reconnect the system to the electrical outlet and turn the system on, including any attached peripherals.
- 13 Enter the System Setup program to confirm that the battery is operating properly. See "Entering the System Setup Program" on page 58.
- 14 Enter the correct time and date in the System Setup program's **Time** and **Date** fields, and re-enter any customized option settings as needed.
- 15 Exit the System Setup program.



# Control Panel Assembly



**NOTE:** The control panel assembly consists of two separate modules—the display module and the control panel circuit board. Use the following instructions to remove and install either module.

## Removing the Control Panel Display Module



**CAUTION: Many repairs may only be done by a certified service technician. You should only perform troubleshooting and simple repairs as authorized in your product documentation, or as directed by the online or telephone service and support team. Damage due to servicing that is not authorized by Dell is not covered by your warranty. Read and follow the safety instructions that came with the product.**

- 1 Turn off the system and attached peripherals, and disconnect the system from the electrical outlet and peripherals.
- 2 Open the system. See "Opening the System" on page 83.
- 3 Disconnect the display module cable from the control panel board. See Figure 3-29.
- 4 Using a knife or a small flat-blade screwdriver, insert the blade beneath the front panel of the display and slide the blade across the bottom to lift the panel outward. See Figure 3-29.
- 5 Bend the panel upward to allow access to the mounting screws.
- 6 Using a T10 Torx driver, remove the two screws that secure the display module to the system chassis.
- 7 Remove the display module from the chassis cutout.

## Installing the Control Panel Display Module

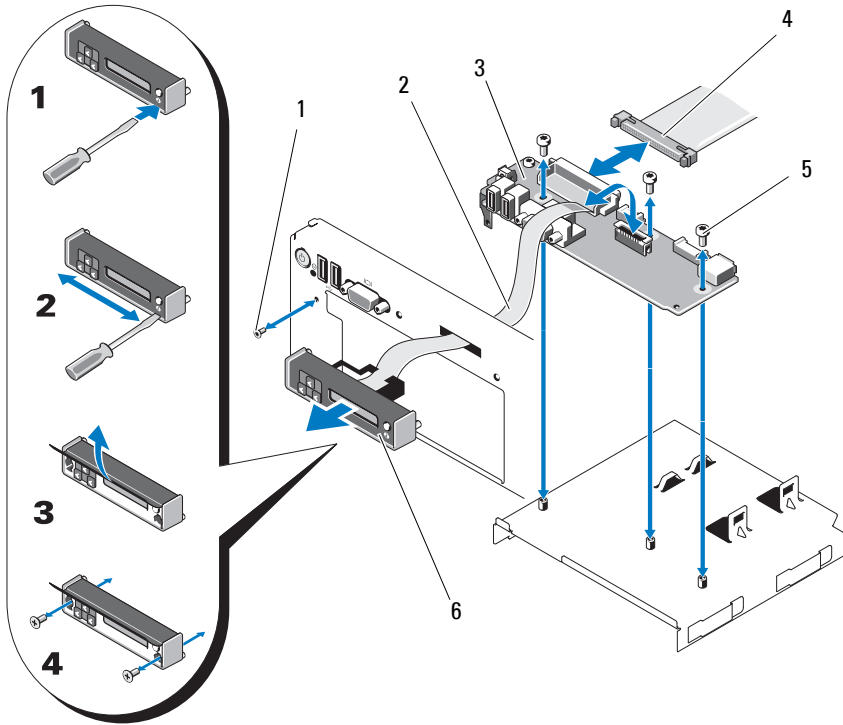


**CAUTION: Many repairs may only be done by a certified service technician. You should only perform troubleshooting and simple repairs as authorized in your product documentation, or as directed by the online or telephone service and support team. Damage due to servicing that is not authorized by Dell is not covered by your warranty. Read and follow the safety instructions that came with the product.**

- 1 Insert the display module into the chassis cutout and secure with the two Torx screws. See Figure 3-29.
- 2 Attach the replacement panel to the front of the display module.


- 3 Connect the display module cable to the control panel board.
- 4 Close the system. See "Closing the System" on page 83.
- 5 Reconnect the system to the power source and turn on the system and attached peripherals.

**Figure 3-29. Removing and Installing the Control Panel**




- |   |                          |   |                      |
|---|--------------------------|---|----------------------|
| 1 | front panel screw (Torx) | 2 | display module cable |
| 3 | control panel board      | 4 | control panel cable  |
| 5 | mounting screws (3 Torx) | 6 | display module       |

## Removing the Control Panel Board


 **CAUTION: Many repairs may only be done by a certified service technician. You should only perform troubleshooting and simple repairs as authorized in your product documentation, or as directed by the online or telephone service and support team. Damage due to servicing that is not authorized by Dell is not covered by your warranty. Read and follow the safety instructions that came with the product.**

- 1 Turn off the system and attached peripherals, and disconnect the system from the electrical outlet and peripherals.
- 2 Open the system. See "Opening the System" on page 83.
- 3 Disconnect the display module cable from the control panel board. See Figure 3-29.
- 4 Disconnect the control panel cable at back of the control panel board. See Figure 3-29.
- 5 Disconnect the internal SD module cable.
- 6 If present, remove the internal USB memory key.

 **CAUTION: Do not pull on the cable to unseat the connector. Doing so can damage the cable.**

- 7 Using a T8 Torx driver, remove the screw on the front panel located beneath the left USB connector. See Figure 3-29.
- 8 Using a T10 Torx driver, remove the three screws that secure the control panel board to the system chassis and remove the board.

## Installing the Control Panel Board


 **CAUTION: Many repairs may only be done by a certified service technician. You should only perform troubleshooting and simple repairs as authorized in your product documentation, or as directed by the online or telephone service and support team. Damage due to servicing that is not authorized by Dell is not covered by your warranty. Read and follow the safety instructions that came with the product.**

- 1 Install the front panel screw in the screw hole located beneath the left USB connector. See Figure 3-29.
- 2 Install the control panel board in the system chassis and secure with the three Torx screws. See Figure 3-29.

- 3 Connect the display module cable to the control panel board.
- 4 Connect the control panel cable to the control panel board.
- 5 Connect the internal SD module cable.
- 6 Install the internal USB memory key.
- 7 Close the system. See "Closing the System" on page 83.
- 8 Reconnect the system to the power source and turn on the system and attached peripherals.


## SAS Backplane (Service Only Procedure)

### Removing the SAS Backplane

 **CAUTION: Many repairs may only be done by a certified service technician. You should only perform troubleshooting and simple repairs as authorized in your product documentation, or as directed by the online or telephone service and support team. Damage due to servicing that is not authorized by Dell is not covered by your warranty. Read and follow the safety instructions that came with the product.**

- 1 If applicable, remove the bezel. See "Removing the Front Bezel" on page 81.
- 2 Turn off the system and attached peripherals, and disconnect the system from the electrical outlet.
- 3 Open the system. See "Opening the System" on page 83.

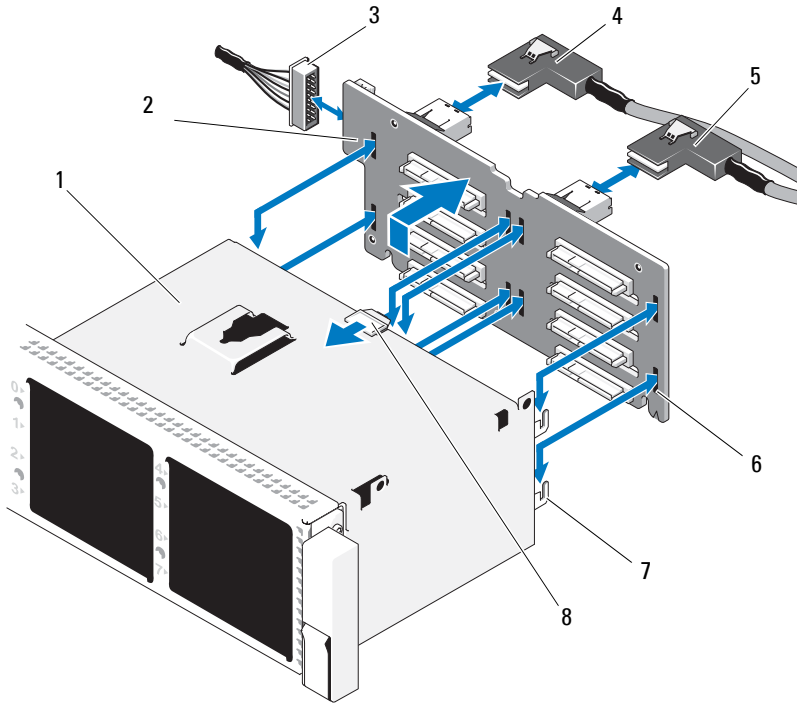
 **CAUTION: To prevent damage to the drives and backplane, you must remove the SAS drives from the system before removing the backplane.**

 **CAUTION: You must note the number of each hard drive and temporarily label them before removal to ensure that you can replace them in the same locations.**

- 4 Remove all hard drives. See "Removing a Hot-Swap Hard Drive" on page 86.
- 5 Disconnect the power cable from the end of the SAS backplane.
- 6 Disconnect the SAS data cables from the backplane.
- 7 While pulling the blue latch toward the front of the system, slide the backplane upward. See Figure 3-30.

- 8 When the backplane cannot slide upward any farther, pull the backplane toward the back of the system to remove it from the retention hooks.
- 9 Lift the board out of the system, being careful to avoid damaging components on the face of the board.
- 10 Place the SAS backplane face down on a work surface.

**Figure 3-30. Removing and Installing a SAS Backplane**



- |   |                               |   |                                 |
|---|-------------------------------|---|---------------------------------|
| 1 | drive bays                    | 2 | SAS backplane board             |
| 3 | power cable from system board | 4 | SAS A cable                     |
| 5 | SAS B cable                   | 6 | securing slots (8)              |
| 7 | securing tabs (7)             | 8 | SAS backplane board release tab |

## Installing a SAS Backplane



**CAUTION:** Many repairs may only be done by a certified service technician. You should only perform troubleshooting and simple repairs as authorized in your product documentation, or as directed by the online or telephone service and support team. Damage due to servicing that is not authorized by Dell is not covered by your warranty. Read and follow the safety instructions that came with the product.

- 1 To install the SAS backplane, lower the backplane into the system, being careful to avoid damaging components on the face of the board.
- 2 Align the slots in the backplane with the retention hooks on the back of the drive bays, then move the backplane forward until the retention hooks fit through the slots in the backplane. See Figure 3-30.
- 3 Slide the backplane downward until the blue retention latch locks into place.
- 4 Connect the SAS data and power cables to the SAS backplane.
- 5 Install the hard drives in their original locations.
- 6 Close the system. See "Closing the System" on page 83.
- 7 Reconnect the system to its electrical outlet and turn the system on, including any attached peripherals.

## System Board

### Removing the System Board



**CAUTION:** Many repairs may only be done by a certified service technician. You should only perform troubleshooting and simple repairs as authorized in your product documentation, or as directed by the online or telephone service and support team. Damage due to servicing that is not authorized by Dell is not covered by your warranty. Read and follow the safety instructions that came with the product.



**CAUTION:** If your system uses the Trusted Platform Module (TPM) with an encryption program, you must supply the recovery key for your data before you can access the encrypted data on your hard drives. See the documentation for your encryption software for more information.



**NOTE:** After replacing the system board, you are required to update the Unified Server Configurator repository to the latest software to restore full functionality. See the Unified Server Configurator user documentation for more information.

- 1 Turn off the system and attached peripherals, and disconnect the system from the electrical outlet.
- 2 Open the system. See "Opening the System" on page 83.
- 3 Remove the power supply(ies). See "Removing a Power Supply" on page 90.
- 4 Remove the cooling shroud. See "Removing the Cooling Shroud" on page 103.
- 5 Remove all expansion cards and the integrated storage controller card. See "Removing an Expansion Card" on page 123 and "Removing the Integrated Storage Controller Card" on page 113.
- 6 If installed, remove the NIC hardware key from the system board. See "NIC Hardware Key" on page 101.
- 7 Remove the two riser boards. See "Removing Expansion-Card Riser 1" on page 124 and "Removing Expansion-Card Riser 2" on page 126.
- 8 Remove the fan bracket. See "Removing the Fan Bracket" on page 107.
- 9 Remove the SAS backplane. See "Removing the SAS Backplane" on page 148.



**CAUTION:** To prevent damage to the drives and backplane, you must remove the SAS drives from the system before removing the backplane.



**CAUTION:** You must note the number of each hard drive and temporarily label them before removal to ensure that you can replace them in the same locations.

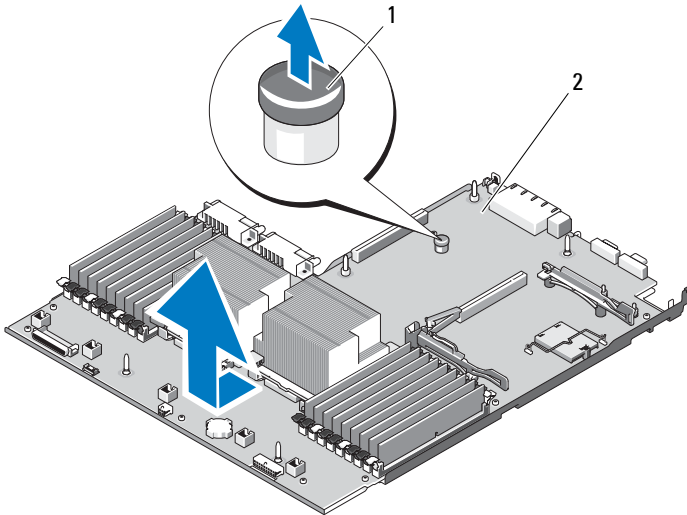
- 10 Disconnect all cables from the system board.
- 11 To remove the system board assembly, pull up the spring-loaded blue retention pin located in the center of the system board, and then slide the system board assembly toward the front end of the chassis.



**WARNING:** Do not lift the system board by the memory modules latches, processor heatsink, or any component on the system board.

- 12 Grasp the system board assembly by the edges of the system board tray, and lift the assembly from the chassis. See Figure 3-31.

**Figure 3-31. System Board Removal**



- 1 system-board tray riser release pin    2 system board

## Installing the System Board



**CAUTION: Many repairs may only be done by a certified service technician. You should only perform troubleshooting and simple repairs as authorized in your product documentation, or as directed by the online or telephone service and support team. Damage due to servicing that is not authorized by Dell is not covered by your warranty. Read and follow the safety instructions that came with the product.**

- 1 Unpack the new system board and remove the label placard that is inserted in the memory module socket.
- 2 Remove the labels from the placard and affix them to the information tag on the front of the system. See Figure 1-1.
- 3 Transfer the processor and heat sink to the new system board. See "Removing a Processor" on page 138.
- 4 Remove the memory modules and transfer them to the same locations on the new board. See "Removing Memory Modules" on page 137 and "Installing Memory Modules" on page 135.



- 5** Angle the system board as you lower it into the chassis and set the board flat inside the chassis.
- 6** Maneuver the system board so that all of the retention hooks on the chassis are inserted into the retention slots on the system board.
- 7** Push the system board toward the back of the chassis until the blue retention pin locks into place.
- 8** If applicable, transfer the NIC hardware key.
- 9** Replace the riser boards. See "Replacing Expansion-Card Riser 1" on page 125 and "Replacing Expansion-Card Riser 2" on page 127.
- 10** Reinstall the integrated storage controller card. See "Installing the Integrated Storage Controller Card" on page 113.
- 11** If applicable, reconnect the RAID battery cable to the storage controller card.
- 12** Reconnect all power and interface cables (see Figure 6-2 for the locations of the connectors on the system board).
- 13** If removed, reinstall the SAS backplane and all hard drives. See "System Board" on page 150.
- 14** Install all expansion cards. See "Installing an Expansion Card" on page 121.
- 15** If applicable, transfer the iDRAC6 Enterprise card to the new system board. See "Installing an iDRAC6 Enterprise Card" on page 98.
- 16** Replace the fan bracket. See "Replacing the Fan Bracket" on page 108.
- 17** Replace the cooling shroud. See "Installing the Cooling Shroud" on page 104.
- 18** Close the system. See "Closing the System" on page 83.
- 19** Reconnect the system to its electrical outlet and turn the system on, including any attached peripherals.



# Troubleshooting Your System

## Safety First—For You and Your System

**△ CAUTION: Many repairs may only be done by a certified service technician. You should only perform troubleshooting and simple repairs as authorized in your product documentation, or as directed by the online or telephone service and support team. Damage due to servicing that is not authorized by Dell is not covered by your warranty. Read and follow the safety instructions that came with the product.**

## Troubleshooting System Startup Failure

If your system halts during startup prior to video imaging or LCD messaging, especially after installing an operating system or reconfiguring your system's hardware, check for the following conditions.

- If you boot the system in BIOS boot mode after installing an operating system in UEFI boot mode, the system will hang. The reverse is also true. You must boot to the same boot mode in which you installed the operating system. See "Using the System Setup Program and UEFI Boot Manager" on page 57.
- Invalid memory configurations could cause the system to halt at startup without any video output. See "System Memory" on page 130.

For all other startup issues, note the LCD panel messages and any system messages that appear on-screen. See "LCD Status Messages" on page 23 and "System Messages" on page 38 for more information.

## Troubleshooting External Connections

Ensure that all external cables are securely attached to the external connectors on your system before troubleshooting any external devices. See Figure 1-1 and Figure 1-4 for the front- and back-panel connectors on your system.

## Troubleshooting the Video Subsystem

- 1 Check the system and power connections to the monitor.
- 2 Check the video interface cabling from the system to the monitor.
- 3 If two monitors are attached to the system, disconnect one monitor. The system supports only one monitor attached to either the front or back video connector.
- 4 Try using a monitor that is known to be working.
- 5 Run the appropriate online diagnostic test. See "Using Online Diagnostics" on page 173.

If the tests run successfully, the problem is not related to video hardware.

If the tests fail, see "Getting Help" on page 189.

## Troubleshooting a USB Device

- 1 Use the following steps to troubleshoot a USB keyboard and/or mouse. For other USB devices, go to step 2.
  - a Disconnect the keyboard and mouse cables from the system briefly and reconnect them.
  - b Connect the keyboard/mouse to the USB port(s) on the opposite side of the system.

If the problem is resolved, restart the system, enter the System Setup program, and check if the nonfunctioning USB ports are enabled.
  - c Replace the keyboard/mouse with another working keyboard/mouse.

If the problem is resolved, replace the faulty keyboard/mouse.

If the problem is not resolved, proceed to the next step to begin troubleshooting the other USB devices attached to the system.
- 2 Power down all attached USB devices and disconnect them from the system.
- 3 Restart the system and, if your keyboard is functioning, enter the system setup program. Verify that all USB ports are enabled. See "Integrated Devices Screen" on page 64.

If your keyboard is not functioning, you can also use remote access.

- 4 Reconnect and power on each USB device one at a time.
- 5 If a device causes the same problem, power down the device, replace the USB cable, and power up the device.

If the problem persists, replace the device.

If all troubleshooting fails, see "Getting Help" on page 189.

## Troubleshooting a Serial I/O Device

- 1 Turn off the system, including any attached peripherals, and disconnect the system from the electrical outlet.
- 2 Swap the serial interface cable with another working cable, and turn on the system and the serial device.

If the problem is resolved, replace the interface cable.

- 3 Turn off the system and the serial device, and swap the device with a comparable device.
- 4 Turn on the system and the serial device.

If the problem is resolved, replace the serial device.

If the problem persists, see "Getting Help" on page 189.

## Troubleshooting a NIC

- 1 Run the appropriate online diagnostic test. See "Using Online Diagnostics" on page 173.
- 2 Restart the system and check for any system messages pertaining to the NIC controller.
- 3 Check the appropriate indicator on the NIC connector. See "NIC Indicator Codes" on page 22.
  - If the link indicator does not light, check all cable connections.
  - If the activity indicator does not light, the network driver files might be damaged or missing.
  - Use another connector on the switch or hub.

If you are using a NIC card instead of an embedded NIC, see the documentation for the NIC card.

- 4 Ensure that the appropriate drivers are installed and the protocols are bound. See the NIC's documentation.
- 5 Enter the System Setup program and confirm that the NIC ports are enabled. See "Integrated Devices Screen" on page 64.
- 6 Ensure that the NICs, hubs, and switches on the network are all set to the same data transmission speed and duplex. See the documentation for each network device.
- 7 Ensure that all network cables are of the proper type and do not exceed the maximum length.

If all troubleshooting fails, see "Getting Help" on page 189.

## Troubleshooting a Wet System



**CAUTION: Many repairs may only be done by a certified service technician. You should only perform troubleshooting and simple repairs as authorized in your product documentation, or as directed by the online or telephone service and support team. Damage due to servicing that is not authorized by Dell is not covered by your warranty. Read and follow the safety instructions that came with the product.**

- 1 Turn off the system and attached peripherals, and disconnect the system from the electrical outlet.
- 2 Open the system. See "Opening the System" on page 83.
- 3 Disassemble components from the system. See "Installing System Components" on page 79.
  - Cooling shroud
  - Hard drives
  - SD cards
  - USB memory key
  - NIC hardware key
  - Internal SD Module
  - Expansion cards and both expansion-card risers
  - Integrated storage controller
  - iDRAC6 Enterprise card

- Power supplies
  - Processor and heat sink
  - Memory modules
  - Fan bracket
- 4 Let the system dry thoroughly for at least 24 hours.
  - 5 Reinstall the processor and heat sink, memory modules, power supplies, cooling shroud, and fan bracket.
  - 6 Close the system. See "Closing the System" on page 83.
  - 7 Reconnect the system to the electrical outlet, and turn on the system.  
If the system does not start properly, see "Getting Help" on page 189.
  - 8 If the system starts properly, shut down the system and reinstall the rest of the components that you removed in step 3. See "Installing an Expansion Card" on page 121.
  - 9 Run the appropriate online diagnostic test. See "Using Online Diagnostics" on page 173.  
If the tests fail, see "Getting Help" on page 189.

## Troubleshooting a Damaged System



**CAUTION: Many repairs may only be done by a certified service technician. You should only perform troubleshooting and simple repairs as authorized in your product documentation, or as directed by the online or telephone service and support team. Damage due to servicing that is not authorized by Dell is not covered by your warranty. Read and follow the safety instructions that came with the product.**

- 1 Turn off the system and attached peripherals, and disconnect the system from the electrical outlet.
- 2 Open the system. See "Opening the System" on page 83.
- 3 Ensure that the following components are properly installed:
  - Expansion cards and both expansion-card risers
  - Power supplies
  - Fans and cooling shroud
  - Processor and heat sink

- Memory modules
  - Hard-drive carriers
- 4 Ensure that all cables are properly connected.
  - 5 Close the system. See "Closing the System" on page 83.
  - 6 Run the system board tests in the system diagnostics. See "Running the System Diagnostics" on page 173.  
If the tests fail, see "Getting Help" on page 189.

## Troubleshooting the System Battery



**CAUTION: Many repairs may only be done by a certified service technician. You should only perform troubleshooting and simple repairs as authorized in your product documentation, or as directed by the online or telephone service and support team. Damage due to servicing that is not authorized by Dell is not covered by your warranty. Read and follow the safety instructions that came with the product.**


- 1 Re-enter the time and date through the System Setup program. See "Using the System Setup Program and UEFI Boot Manager" on page 57.
- 2 Turn off the system and disconnect it from the electrical outlet for at least one hour.
- 3 Reconnect the system to the electrical outlet and turn on the system.
- 4 Enter the System Setup program.

If the date and time are not correct in the System Setup program, replace the battery. See "System Battery" on page 143.


If the problem is not resolved by replacing the battery, see "Getting Help" on page 189.




## Troubleshooting Power Supplies

 **CAUTION:** At least one power supply must be installed for the system to operate. Operating the system with only one power supply installed for extended periods of time without a power-supply blank installed in the PS2 power-supply bay can cause the system to overheat.

- 1 Identify the faulty power supply by the power supply's status indicator. See "Power Indicator Codes" on page 21.

 **CAUTION:** If troubleshooting a power supply mismatch error, replace *only* the power supply with the flashing indicator. Swapping the opposite power supply to make a matched pair can result in an error condition and unexpected system shutdown. To change from a High Output configuration to an Energy Smart configuration or vice versa, you must power down the system.


- 2 Reseat the power supply by removing and reinstalling it. See "Removing a Power Supply" on page 90 and "Replacing a Power Supply" on page 91.

 **NOTE:** After installing a power supply, allow several seconds for the system to recognize the power supply and to determine if it is working properly. The status indicator turns green to signify that the power supply is functioning properly.

If the problem persists, replace the faulty power supply with the same type of power supply.

- 3 If the problem persists, see "Getting Help" on page 189.

## Troubleshooting System Cooling Problems

 **CAUTION:** Many repairs may only be done by a certified service technician. You should only perform troubleshooting and simple repairs as authorized in your product documentation, or as directed by the online or telephone service and support team. Damage due to servicing that is not authorized by Dell is not covered by your warranty. Read and follow the safety instructions that came with the product.

Ensure that none of the following conditions exist:

- System cover, cooling shroud, drive blank, power supply blank (in single power supply configurations), or front or back filler panel is removed.
- FAN5 blank or heat sink blank is removed.

- The expansion card installation guidelines have not been followed. See "Expansion Card Installation Guidelines" on page 120.
- Ambient temperature is too high. See your *Getting Started Guide* for the system's operating temperature requirements.
- External airflow is obstructed.
- Cables inside the system obstruct airflow.
- An individual cooling fan is removed or has failed. See "Troubleshooting a Fan" on page 162.

## Troubleshooting a Fan



**CAUTION:** Many repairs may only be done by a certified service technician. You should only perform troubleshooting and simple repairs as authorized in your product documentation, or as directed by the online or telephone service and support team. Damage due to servicing that is not authorized by Dell is not covered by your warranty. Read and follow the safety instructions that came with the product.

- 1 Open the system. See "Opening the System" on page 83.



**CAUTION:** The cooling fans are hot-swappable. To maintain proper cooling while the system is on, only replace one fan at a time.

- 2 Locate the faulty fan indicated by the LCD panel or the diagnostic software.
- 3 Reseat the fan. See "Removing a Cooling Fan" on page 105 and "Replacing a Cooling Fan" on page 106.



**NOTE:** Wait for at least 30 seconds for the system to recognize the fan and determine whether it is working properly.

- 4 If the problem is not resolved, install a new fan.  
If the replacement fan does not operate, see "Getting Help" on page 189.

# Troubleshooting System Memory



**CAUTION:** Many repairs may only be done by a certified service technician. You should only perform troubleshooting and simple repairs as authorized in your product documentation, or as directed by the online or telephone service and support team. Damage due to servicing that is not authorized by Dell is not covered by your warranty. Read and follow the safety instructions that came with the product.



**NOTE:** Invalid memory configurations can cause your system to halt at startup without video output. See "General Memory Module Installation Guidelines" on page 131 and verify that your memory configuration complies with all applicable guidelines.

- 1 If the system is operational, run the appropriate online diagnostic test. See "Using Online Diagnostics" on page 173.

If diagnostics indicates a fault, follow the corrective actions provided by the diagnostic program.

- 2 If the system is not operational, turn off the system and attached peripherals, and unplug the system from the power source. Wait at least 10 seconds and then reconnect the system to power.
- 3 Turn on the system and attached peripherals and note the messages on the screen or LCD panel.

Go to step 14 if an error message appears indicating a fault with a specific memory module.

- 4 Enter the System Setup program and check the system memory setting. See "Memory Settings Screen" on page 61. Make any changes to the memory settings, if needed.

If the memory settings match the installed memory but a problem is still indicated, go to step 14.

- 5 Turn off the system and attached peripherals, and disconnect the system from the electrical outlet.
- 6 Open the system. See "Opening the System" on page 83.
- 7 Remove the cooling shroud. See "Removing the Cooling Shroud" on page 103.
- 8 Check the memory channels and ensure that they are populated correctly. See "General Memory Module Installation Guidelines" on page 131.

- 9** Reseat the memory modules in their sockets. See "Installing Memory Modules" on page 135.
- 10** Replace the cooling shroud. See "Installing the Cooling Shroud" on page 104.
- 11** Close the system. See "Closing the System" on page 83.
- 12** Reconnect the system to its electrical outlet, and turn on the system and attached peripherals.
- 13** Enter the System Setup program and check the system memory setting. See "Memory Settings Screen" on page 61.  
If the problem is not resolved, proceed with the next step.
- 14** Turn off the system and attached peripherals, and disconnect the system from the power source.
- 15** Open the system. See "Opening the System" on page 83.
- 16** Remove the cooling shroud. See "Removing the Cooling Shroud" on page 103.
- 17** If a diagnostic test or error message indicates a specific memory module as faulty, swap or replace the module.
- 18** To troubleshoot an unspecified faulty memory module, replace the memory module in the first DIMM socket with a module of the same type and capacity. See "Installing Memory Modules" on page 135.
- 19** Replace the cooling shroud. See "Installing the Cooling Shroud" on page 104.
- 20** Close the system. See "Closing the System" on page 83.
- 21** Reconnect the system to its electrical outlet, and turn on the system and attached peripherals.
- 22** As the system boots, observe any error message that appears on the screen or the LCD panel on the front of the system.
- 23** If the memory problem is still indicated, repeat step 14 through step 22 for each memory module installed.  
If the problem persists after all memory modules have been checked, see "Getting Help" on page 189.

## Troubleshooting an Internal SD Card




**CAUTION: Many repairs may only be done by a certified service technician. You should only perform troubleshooting and simple repairs as authorized in your product documentation, or as directed by the online or telephone service and support team. Damage due to servicing that is not authorized by Dell is not covered by your warranty. Read and follow the safety instructions that came with the product.**

- 1** Enter the System Setup program and ensure that the internal SD card port is enabled. See "Integrated Devices Screen" on page 64.
- 2** Turn off the system, including any attached peripherals, and disconnect the system from the electrical outlet.
- 3** Open the system. See "Opening the System" on page 83.
- 4** Reseat the internal SD module cable. See "Installing the Internal SD Module" on page 92.
- 5** Locate the SD card and reseat it. See "Removing the Internal SD Flash Card" on page 95 and "Installing the Internal SD Flash Card" on page 94.
- 6** Close the system. See "Closing the System" on page 83.
- 7** Turn on the system and attached peripherals and check if the SD card is functioning.
- 8** If the problem is not resolved, repeat step 2 and step 3.
- 9** Insert a different SD card that you know works properly.
- 10** Close the system. See "Closing the System" on page 83.
- 11** Turn on the system and attached peripherals and check if the SD card is functioning.

If the problem is not resolved, see "Getting Help" on page 189.

# Troubleshooting an Internal USB Memory Key

 **CAUTION:** Many repairs may only be done by a certified service technician. You should only perform troubleshooting and simple repairs as authorized in your product documentation, or as directed by the online or telephone service and support team. Damage due to servicing that is not authorized by Dell is not covered by your warranty. Read and follow the safety instructions that came with the product.

- 1 Enter the System Setup program and ensure that the internal USB key port is enabled. See "Integrated Devices Screen" on page 64.
- 2 Turn off the system, including any attached peripherals, and disconnect the system from the electrical outlet.
- 3 Open the system. See "Opening the System" on page 83.
- 4 Locate the internal USB key and reseat it. See "Internal USB Memory Key" on page 95.
- 5 Close the system. See "Closing the System" on page 83.
- 6 Turn on the system and attached peripherals and check if the USB key is functioning.
- 7 If the problem is not resolved, repeat step 2 and step 3.
- 8 Insert a different USB key that you know works properly.
- 9 Close the system. See "Closing the System" on page 83.
- 10 Turn on the system and attached peripherals and check if the USB key is functioning.  
If the problem is not resolved, see "Getting Help" on page 189.

# Troubleshooting an Optical Drive




**CAUTION: Many repairs may only be done by a certified service technician. You should only perform troubleshooting and simple repairs as authorized in your product documentation, or as directed by the online or telephone service and support team. Damage due to servicing that is not authorized by Dell is not covered by your warranty. Read and follow the safety instructions that came with the product.**

- 1** If applicable, remove the bezel. See "Removing the Front Bezel" on page 81.
- 2** Try using a different DVD.
- 3** Ensure that the device drivers for the optical drive are installed and are configured correctly
- 4** Enter the System Setup program and ensure that the drive's controller is enabled. See "Using the System Setup Program and UEFI Boot Manager" on page 57.
- 5** Run the appropriate online diagnostic test. See "Using Online Diagnostics" on page 173.
- 6** Turn off the system and attached peripherals, and disconnect the system from the electrical outlet.
- 7** Open the system. See "Opening the System" on page 83.
- 8** Ensure that the interface cable is securely connected to the optical drive and to the system board. See "Optical Drive" on page 109.
- 9** Ensure that a power cable is properly connected to the drive and the system board.
- 10** Close the system. See "Closing the System" on page 83.
- 11** Reconnect the system to the electrical outlet, and turn on the system and attached peripherals.

If the problem is not resolved, see "Getting Help" on page 189.

# Troubleshooting a Hard Drive

 **CAUTION:** Many repairs may only be done by a certified service technician. You should only perform troubleshooting and simple repairs as authorized in your product documentation, or as directed by the online or telephone service and support team. Damage due to servicing that is not authorized by Dell is not covered by your warranty. Read and follow the safety instructions that came with the product.

 **CAUTION:** This troubleshooting procedure can destroy data stored on the hard drive. Before you proceed, back up all files on the hard drive.

- 1 Run the appropriate online diagnostics test. See "Using Online Diagnostics" on page 173.  
Depending on the results of the diagnostics test, proceed as needed through the following steps.
- 2 Remove the bezel. See "Removing the Front Bezel" on page 81.
- 3 If your hard drives are configured in a RAID array, perform the following steps:
  - a Restart the system and enter the host adapter configuration utility program by pressing <Ctrl><R> for a PERC controller.  
See the documentation supplied with the host adapter for information about the configuration utility.
  - b Ensure that the hard drive(s) have been configured correctly for the RAID array.
  - c Take the hard drive offline and then reseal the hard drive.  
See "Removing a Hot-Swap Hard Drive" on page 86.
  - d Exit the configuration utility and allow the system to boot to the operating system.
- 4 Ensure that the required device drivers for your controller card are installed and are configured correctly. See the operating system documentation for more information.



- 5 Restart the system, enter the System Setup program, and verify that the controller is enabled and the drives appear in the System Setup program. See "Using the System Setup Program and UEFI Boot Manager" on page 57.

If the problem persists, see "Troubleshooting a Storage Controller" on page 169.

## Troubleshooting a Storage Controller



**NOTE:** When troubleshooting a PERC controller, also see the documentation for your operating system and the controller.

- 1 Run the appropriate online diagnostic test. See "Using Online Diagnostics" on page 173.
- 2 Enter the System Setup program and ensure that the PERC controller is enabled. See "Using the System Setup Program and UEFI Boot Manager" on page 57.
- 3 Restart the system and press <Ctrl><R> for a PERC controller to enter the configuration utility program:  
See the controller's documentation for information about configuration settings.
- 4 Check the configuration settings, make any necessary corrections, and restart the system.



**CAUTION:** Many repairs may only be done by a certified service technician. You should only perform troubleshooting and simple repairs as authorized in your product documentation, or as directed by the online or telephone service and support team. Damage due to servicing that is not authorized by Dell is not covered by your warranty. Read and follow the safety instructions that came with the product.

- 5 Turn off the system and attached peripherals, and disconnect the system from its electrical outlet.
- 6 Open the system. See "Opening the System" on page 83.
- 7 Ensure that the controller card is firmly seated into the expansion-card connector. See "Installing the Integrated Storage Controller Card" on page 113.

- 8 If you have a battery-cached PERC controller, ensure that the RAID battery is properly connected and, if applicable, the memory module on the PERC card is properly seated.
- 9 Verify that the cable connections between the SAS backplane and the integrated storage controller are correct. See "Installing the Integrated Storage Controller Card" on page 113 and Figure 6-3.
- 10 Ensure that the cables are firmly connected to the storage controller and the SAS backplane board.
- 11 Close the system. See "Closing the System" on page 83.
- 12 Reconnect the system to its electrical outlet, and turn on the system and attached peripherals.

If the problem persists, see "Getting Help" on page 189.

## Troubleshooting Expansion Cards



**CAUTION:** Many repairs may only be done by a certified service technician. You should only perform troubleshooting and simple repairs as authorized in your product documentation, or as directed by the online or telephone service and support team. Damage due to servicing that is not authorized by Dell is not covered by your warranty. Read and follow the safety instructions that came with the product.




**NOTE:** When troubleshooting an expansion card, see the documentation for your operating system and the expansion card.

- 1 Run the appropriate online diagnostic test. See "Using Online Diagnostics" on page 173.
- 2 Turn off the system and attached peripherals, and disconnect the system from the electrical outlet.
- 3 Open the system. See "Opening the System" on page 83.
- 4 Verify that the installed expansion cards are compliant with the expansion-card installation guidelines. See "Expansion Card Installation Guidelines" on page 120.
- 5 Reseat any expansion card that is not firmly seated in its connector. See "Installing an Expansion Card" on page 121.
- 6 Close the system. See "Closing the System" on page 83.

- 7** Reconnect the system to the electrical outlet, and turn on the system and attached peripherals.  
If the problem is not resolved, proceed to step 8.
- 8** Turn off the system and attached peripherals, and disconnect the system from the electrical outlet.
- 9** Open the system. See "Opening the System" on page 83.
- 10** Remove all expansion cards installed in the system. See "Removing an Expansion Card" on page 123.
- 11** Reseat the expansion-card risers to the system board. See "Expansion Cards and Expansion-Card Risers" on page 120.
- 12** Close the system. See "Closing the System" on page 83.
- 13** Reconnect the system to the electrical outlet, and turn on the system and attached peripherals.
- 14** Run the appropriate online diagnostic test.  
If the tests fail, see "Getting Help" on page 189.
- 15** For each expansion card you removed in step 10, perform the following steps:
  - a** Turn off the system and attached peripherals, and disconnect the system from the electrical outlet.
  - b** Open the system. See "Opening the System" on page 83.
  - c** Reinstall one of the expansion cards.
  - d** Close the system. See "Closing the System" on page 83.
  - e** Run the appropriate diagnostic test.  
If the tests fail, see "Getting Help" on page 189.

# Troubleshooting the Processor

 **CAUTION: Many repairs may only be done by a certified service technician. You should only perform troubleshooting and simple repairs as authorized in your product documentation, or as directed by the online or telephone service and support team. Damage due to servicing that is not authorized by Dell is not covered by your warranty. Read and follow the safety instructions that came with the product.**

- 1 Run the appropriate online diagnostics test. See "Using Online Diagnostics" on page 173.
- 2 Turn off the system and attached peripherals, and disconnect the system from the electrical outlet.
- 3 Open the system. See "Opening the System" on page 83.
- 4 Remove the cooling shroud. See "Removing the Cooling Shroud" on page 103.
- 5 Ensure that each processor and heat sink are properly installed. See "Installing a Processor" on page 141.
- 6 Replace the cooling shroud. See "Installing the Cooling Shroud" on page 104.
- 7 Close the system. See "Closing the System" on page 83.
- 8 Reconnect the system to the electrical outlet, and turn on the system and attached peripherals.
- 9 Run the appropriate online diagnostic test.  
If the test fails, the processor is faulty. See "Getting Help" on page 189.

# Running the System Diagnostics

If you experience a problem with your system, run the diagnostics before calling for technical assistance. The purpose of the diagnostics is to test your system's hardware without requiring additional equipment or risking data loss. If you are unable to fix the problem yourself, service and support personnel can use diagnostics test results to help you solve the problem.

## Using Online Diagnostics

To assess a system problem, first use the Online Diagnostics. Online Diagnostics is a suite of diagnostic programs, or test modules, that include diagnostic tests on chassis and storage components such as hard drives, physical memory, communications ports, NICs, CMOS, and more. If you are unable to identify the problem using the Online Diagnostics, then use the system diagnostics.

The files required to run online diagnostics for systems running supported Linux operating systems are available at [support.dell.com](http://support.dell.com) and on the CDs that came with your system. For information about using diagnostics, see the *Dell Online Diagnostics User's Guide*.

## Embedded System Diagnostics Features

The system diagnostics provides a series of menus and options for particular device groups or devices. The system diagnostics menus and options allow you to:

- Run tests individually or collectively
- Control the sequence of tests
- Repeat tests
- Display, print, or save test results
- Temporarily suspend testing if an error is detected or terminate testing when a user-defined error limit is reached
- View help messages that briefly describe each test and its parameters

- View status messages that inform you if tests are completed successfully
- View error messages that inform you of problems encountered during testing.

## When to Use the Embedded System Diagnostics

If a major component or device in the system does not operate properly, component failure may be indicated. As long as the processor and the system's input/output devices are functioning, you can use the system diagnostics to help identify the problem.

## Running the Embedded System Diagnostics

The embedded system diagnostics program is run from the iDRAC6 Express System Services menu.

 **CAUTION: Use the system diagnostics to test only your system. Using this program with other systems may cause invalid results or error messages.**

- 1 As the system boots, press <F10>.
- 2 Select **Diagnostics** from the System Services menu.
- 3 Select **Launch Diagnostics**.
- 4 From the **Diagnostics** main menu, select **Run Diags**, or select **MpMemory** if you are troubleshooting memory.

The **Diagnostics** menu allows you to run all or specific diagnostics tests, or to exit.

## System Diagnostics Testing Options

Select the testing option in the Main Menu window.

Testing Option	Function
Express Test	Performs a quick check of the system. This option runs device tests that do not require user interaction.
Extended Test	Performs a more thorough check of the system. This test can take an hour or longer.

Testing Option	Function
Custom Test	Tests a particular device.
Information	Displays test results.

## Using the Custom Test Options

When you select **Custom Test** in the **Main Menu** window, the **Customize** window allows you to select the device(s) to be tested, select specific options for testing, and view the test results.

### Selecting Devices for Testing

The left side of the **Customize** window lists devices that can be tested. Click the (+) next to a device or module to view its components. Click (+) on any component to view the tests that are available. Clicking a device, rather than its components, selects all of the components of the device for testing. If an item is grayed-out and you wish to run that test, you can select it by highlighting the item and pressing the spacebar.



**NOTE:** After you select all the devices and components that you want to test, highlight **All Devices** and then click **Run Tests**.

### Selecting Diagnostics Options

From the **Diagnostics Options** area, select the test(s) you want to run on a device.

- **Non-Interactive Tests Only**—Runs only tests that require no user intervention.
- **Quick Tests Only**—Runs only the quick tests on the device.
- **Show Ending Timestamp**—Time stamps the test log.
- **Test Iterations**—Selects the number of times the test is run.
- **Continue on Failure**—Enables the tests to continue without user intervention in the event that one of the tests has failed.
- **Log output file pathname**—Enables you to specify the diskette drive or USB memory key where the test log file is saved. You cannot save the file to a hard drive.


## Viewing Information and Results

The following tabs in the **Customize** window provide information about the test and the test results.

- **Results** —Displays the test that ran and the result.
- **Errors** —Displays any errors that occurred during the test.
- **Help** —Displays information about the currently selected device, component, or test.
- **Configuration** —Displays basic configuration information about the currently selected device.
- **Parameters** —Displays parameters that you can set for the test.



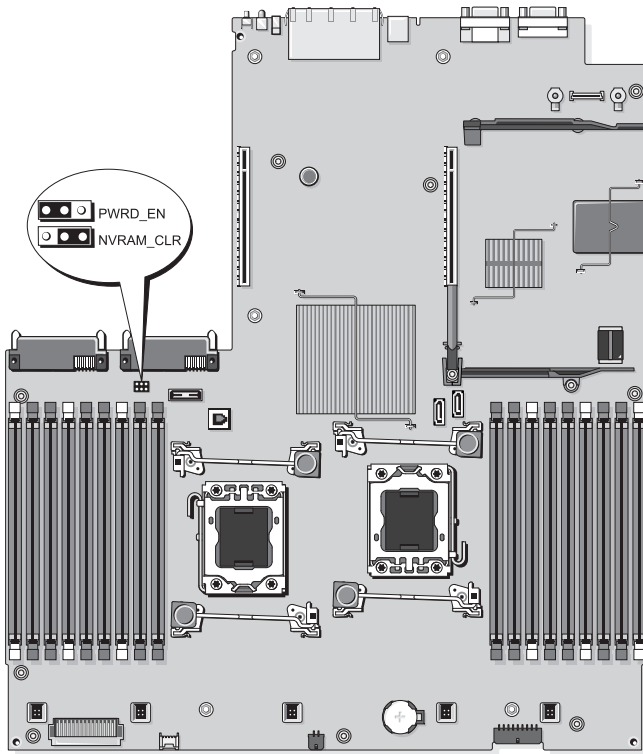
# Jumpers and Connectors



 **CAUTION:** Many repairs may only be done by a certified service technician. You should only perform troubleshooting and simple repairs as authorized in your product documentation, or as directed by the online or telephone service and support team. Damage due to servicing that is not authorized by Dell is not covered by your warranty. Read and follow the safety instructions that came with the product.



## System Board Jumpers

For information on resetting the password jumper to disable a password, see "Disabling a Forgotten Password" on page 186.

**Figure 6-1. System Board Jumpers**

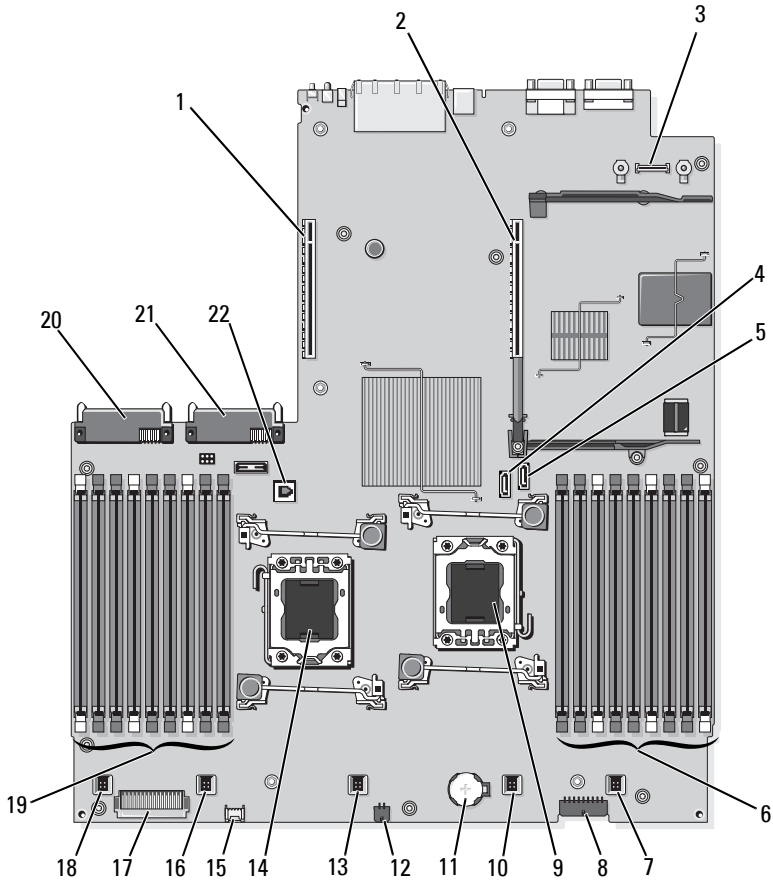


Jumper	Setting	Description
PWRD_EN		Pins 2 and 4 The password feature is enabled. (default)
		Pins 4 and 6 The password feature is disabled and iDRAC6 local access is unlocked at the next AC power cycle.

<b>Jumper</b>	<b>Setting</b>	<b>Description</b>
NVRAM_CLR		Pins 3 and 5 (default) The configuration settings are retained at system boot.
		Pins 1 and 3 The configuration settings are cleared at the next system boot. If the configuration settings become corrupted to the point where the system will not boot, install the jumper and boot the system. Remove the jumper before restoring the configuration information.

# System Board Connectors

Figure 6-2. System Board Connectors

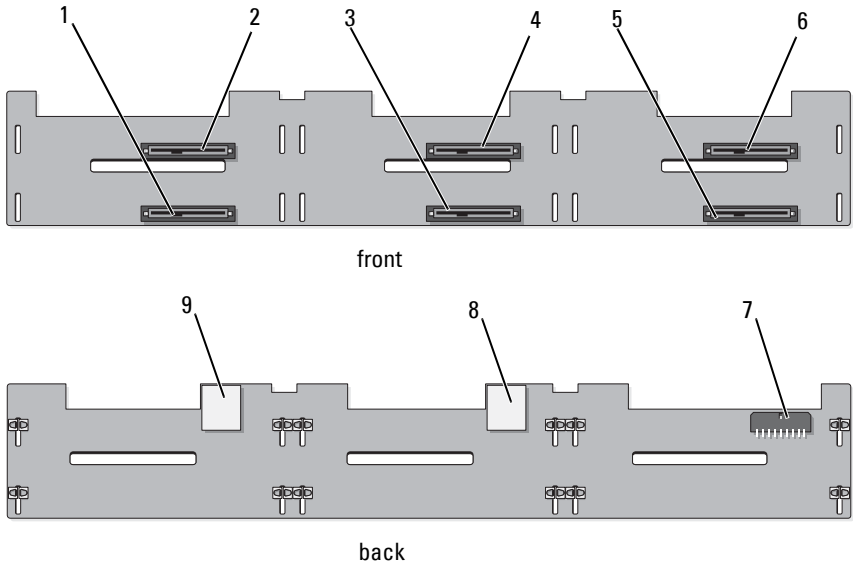


<b>Item</b>	<b>Connector</b>	<b>Description</b>
1	RISER2	expansion-card riser 2 connector
2	RISER1	expansion-card riser 1 connector
3	iDRAC6	iDRAC6 Enterprise card connector
4	SATA_A	SATA A connector
5	SATA_B	SATA B connector
6	B1	memory module slot B1 (white release lever)
	B4	memory module slot B4
	B7	memory module slot B7
	B2	memory module slot B2 (white release lever)
	B5	memory module slot B5
	B8	memory module slot B8
	B3	memory module slot B3 (white release lever)
	B6	memory module slot B6
	B9	memory module slot B9
7	FAN5	System cooling fan
8	BP_PWR	Backplane power connector
9	CPU2	Processor 0
10	FAN4	System cooling fan
11	BATTERY	System battery
12	DVD/TBU_PWR	Power connector for optical drive and tape backup unit
13	FAN3	System cooling fan
14	CPU1	Processor 1
15	CTRL_USB	Control panel USB interface connector
16	FAN2	System cooling fan
17	CTRL_PNL	Control panel interface connector
18	FAN1	System cooling fan

<b>Item</b>	<b>Connector</b>	<b>Description</b>
19	A1	memory module slot A1 (white release lever)
	A4	memory module slot A4
	A7	memory module slot A7
	A2	memory module slot A2 (white release lever)
	A5	memory module slot A5
	A8	memory module slot A8
	A3	memory module slot A3 (white release lever)
	A6	memory module slot A6
	A9	memory module slot A9
20	PWR2	Power supply connector for PS2
21	PWR1	Power supply connector for PS1
22	ISCSI_KEY	NIC hardware key

# SAS Backplane Board Connectors

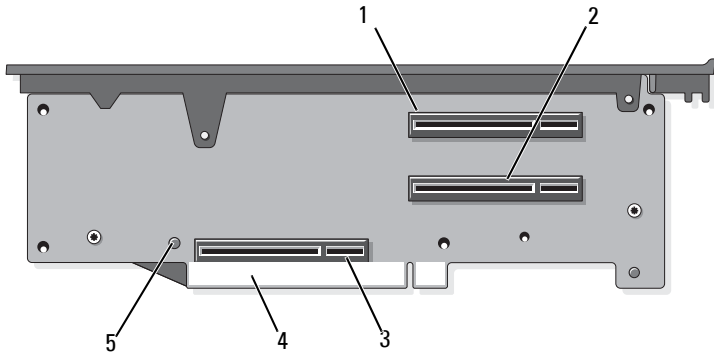
Figure 6-3. SAS Backplane Board



- |   |                          |   |                   |
|---|--------------------------|---|-------------------|
| 1 | drive 1 connector        | 2 | drive 0 connector |
| 3 | drive 3 connector        | 4 | drive 2 connector |
| 5 | drive 5 connector        | 6 | drive 4 connector |
| 7 | backplane power (BP_PWR) | 8 | SAS A connector   |
| 9 | SAS B connector          |   |                   |

# Expansion-Card Riser-Board Components and PCIe Buses

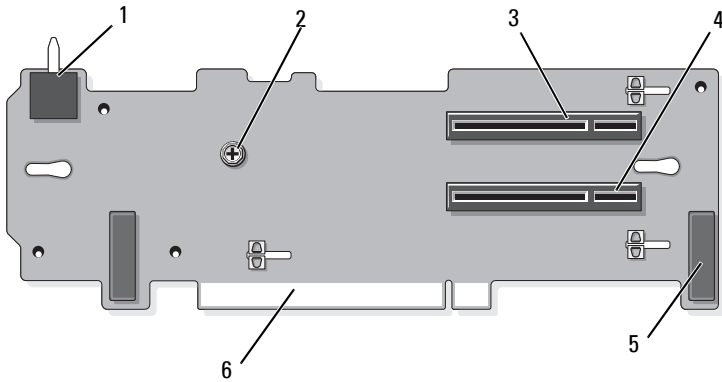
Figure 6-4. PCIe Expansion-Card Riser 1 Components



- |  |   |
|--|---|
| 1 slot 1 PCIe - x4 link (full-height, 30.99-cm [12.2"] length) | 2 slot 2 PCIe - x4 link (low profile, 24.13-cm [9.5"] length) |
| 3 storage controller socket                                    | 4 card edge connector   |
| 5 release button   |   |

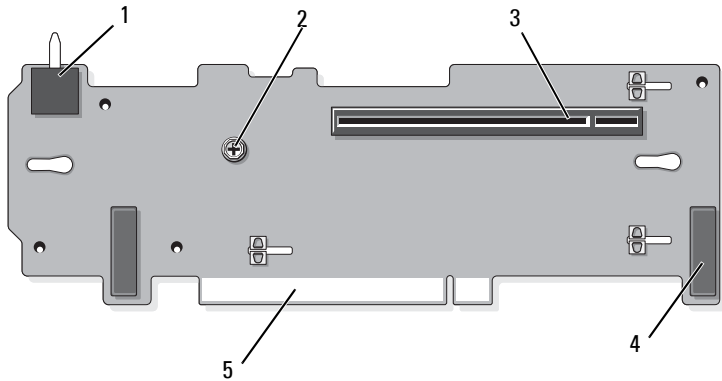


**Figure 6-5. Standard PCIe Expansion-Card Riser 2 Components**



- |   |   |   |   |
|---|---|---|---|
| 1 | chassis intrusion switch                                  | 2 | screw   |
| 3 | slot 3 PCIe x8 link (full-height, 24.13-cm [9.5"] length) | 4 | slot 4 PCIe x8 link (full-height, 24.13-cm [9.5"] length) |
| 5 | pin collars (2)   | 6 | card edge connector                                       |

**Figure 6-6. Optional PCIe x16 Expansion-Card Riser 2 Components**



- |   |  |   |                 |
|---|--|---|-----------------|
| 1 | chassis intrusion switch                                       | 2 | plunger         |
| 3 | slot 3 PCIe x16 link (full-height, 24.13-<br>cm [9.5"] length) | 4 | pin collars (2) |
| 5 | card edge connector  |   |                 |

## Disabling a Forgotten Password

The system's software security features include a system password and a setup password, which are discussed in detail in "Using the System Setup Program and UEFI Boot Manager" on page 57. The password jumper enables these password features or disables them and clears any password(s) currently in use.

**CAUTION:** Many repairs may only be done by a certified service technician. You should only perform troubleshooting and simple repairs as authorized in your product documentation, or as directed by the online or telephone service and support team. Damage due to servicing that is not authorized by Dell is not covered by your warranty. Read and follow the safety instructions that came with the product.

- 1 Turn off the system, including any attached peripherals, and disconnect the system from the electrical outlet.
- 2 Open the system. See "Opening the System" on page 83.
- 3 Move the password jumper plug to the disabled position (pins 4 and 6).

See Figure 6-1 to locate the password jumper (labeled “PWRD\_EN”) on the system board.

- 4 Close the system. See "Closing the System" on page 83.
- 5 Reconnect your system and peripherals to their electrical outlets, and turn on the system.

The existing passwords are not disabled (erased) until the system boots with the password jumper plug in the disabled position. However, before you assign a new system and/or setup password, you must reset the jumper plug to the enabled position.



**NOTE:** If you assign a new system and/or setup password with the jumper plug still in the disabled position, the system disables the new password(s) the next time it boots.

- 6 Turn off the system, including any attached peripherals, and disconnect the system from the electrical outlet.
- 7 Open the system. See "Opening the System" on page 83.
- 8 Move the password jumper plug to the enabled position (pins 2 and 4).
- 9 Close the system. See "Closing the System" on page 83.
- 10 Reconnect your system and peripherals to their electrical outlets, and turn on the system.
- 11 Assign a new system and/or setup password.

To assign a new password using the System Setup program, see "Assigning a System Password" on page 73.



# Getting Help

## Contacting Dell

For customers in the United States, call 800-WWW-DELL (800-999-3355).



**NOTE:** If you do not have an active Internet connection, you can find contact information on your purchase invoice, packing slip, bill, or Dell product catalog.

Dell provides several online and telephone-based support and service options. Availability varies by country and product, and some services may not be available in your area. To contact Dell for sales, technical support, or customer service issues:

- 1 Visit [support.dell.com](https://support.dell.com).
- 2 Verify your country or region in the **Choose A Country/Region** drop-down menu at the bottom of the page.
- 3 Click **Contact Us** on the left side of the page.
- 4 Select the appropriate service or support link based on your need.  
Choose the method of contacting Dell that is convenient for you.



# Index

## A

Advanced ECC memory mode, 132

## B

back panel features, 19

backplane  
*See* SAS backplane.

battery (RAID)  
installing, 116  
removing, 116

battery (system)  
replacing, 143  
troubleshooting, 160

BIOS boot mode, 57

blank  
hard drive, 85  
power supply, 92

boot mode, 57

## C

cable retention bracket  
installing, 119  
removing, 118

cable routing, 118

cabling

cable routing, 118  
optical drive, 109  
storage controller (four 3.5-in HDD chassis), 115

connectors

expansion-card riser 1, 184  
expansion-card riser 2, 185-186  
NIC, 20  
SAS backplane board, 183  
serial, 20  
system board, 180  
USB, 12  
video, 12

contacting Dell, 189

control panel assembly  
features, 12  
LCD panel features, 14

control panel board  
installing, 147  
removing, 147

control panel display module  
installing, 145  
removing, 145

cooling fan  
removing, 105  
replacing, 106  
troubleshooting, 162

cooling shroud  
installing cooling shroud, 104

- removing, 103

cover

- closing, 83
- opening, 83

## D

damaged systems

- troubleshooting, 159

Dell

- contacting, 189

diagnostics

- testing options, 174
- using Online Diagnostics, 173

DIMMs

- See* memory modules (DIMMs).

drive blank

- installing, 86
- removing, 85

drive carrier

- hard drive, 87

DVD drive

- See* optical drive.

## E

error messages, 58

expansion cards

- See* PCIe expansion cards.

expansion-card riser 1

- connectors, 184
- installing, 125

- removing, 124

expansion-card riser 2

- connectors, 185-186
- installing, 127
- installing into expansion-card bracket, 130
- removing, 126
- removing from expansion-card bracket, 128

## F

fan

- removing, 105
- replacing, 106

fan brackets

- removing, 107
- replacing, 108

front-panel features, 12

## G

guidelines

- expansion card installation, 120
- memory installation, 131

## H

hard drive

- drive carrier, 87
- installing, 86
- removing, 86
- troubleshooting, 168



- heat sink, 139
- hot-swap
  - cooling fans, 105
  - hard drives, 84
  - power supplies, 90

## I

- iDRAC Configuration Utility, 76

- iDRAC6 Enterprise card
  - installing, 98
  - removing, 99

- indicators
  - back panel, 19
  - front-panel, 12
  - NIC, 22
  - power, 12, 21

- information tag
  - removing, 82
  - replacing, 82

- installing
  - cable retention bracket, 119
  - control panel board, 147
  - control panel display module, 145
  - cooling shroud, 104
  - expansion-card riser 1, 125
  - hard drive blank, 86
  - hard drives, 86
  - iDRAC6 Enterprise card, 98
  - internal SD flash card, 94
  - internal SD module, 92
  - internal USB memory key, 95
  - memory modules, 135
  - optical drive, 109

- PCIe expansion cards, 121
- power supply blank, 92
- processor, 141
- RAID battery, 116
- riser 2 into expansion-card bracket, 130
- SAS backplane board, 150
- SD card, 94
- storage controller, 113
- VFlash SD card, 100

- Integrated Dell Remote Access Controller
  - See* iDRAC6 Enterprise card.

- integrated storage controller
  - See* storage controller.

- internal SD flash card
  - installing, 94

- internal SD module
  - installing, 92
  - removing, 94

- internal USB memory key, 95
  - troubleshooting, 166

## J

- jumpers (system board), 177

## K

- keyboard
  - troubleshooting, 156

## L

LAN-on-motherboard (LOM)

*See* NICs.

LCD panel

features, 14

menus, 15

## M

memory

troubleshooting, 163

Memory Mirroring memory

mode, 132

memory mode

Advanced ECC, 132

Memory Mirroring, 132

Optimizer, 132

memory modules (DIMMs)

configuring, 131

installing, 135

RDIMM configurations, 133

removing, 137

UDIMM configurations, 121,  
135

messages

error messages, 58

status LCD, 23

system, 38

warning, 55

microprocessor

*See* processor.

## N

NIC hardware key, 101

NICs

connectors, 20

hardware key, 101

indicators, 22

troubleshooting, 157

## O

optical drive

installing, 109

removing, 109

troubleshooting, 167

Optimizer memory mode, 132

## P

password

disabling, 186

setup, 75

system, 73

PCIe expansion cards

installing, 121

removing, 123

riser boards, 184

troubleshooting, 170

POST

accessing system features, 11

power indicators, 12, 21

power supplies

indicators, 21

- removing, 90
- replacing, 91
- troubleshooting, 161

power supply blank, 92

processor

- installing, 141
- removing, 138
- troubleshooting, 172
- upgrades, 138

PSU

- See* power supply.

## R

RAID battery

- installing, 116
- removing, 116

removing

- cable retention bracket, 118
- control panel board, 147
- control panel display module, 145
- cooling fan, 105
- cooling shroud, 103
- expansion-card riser 1, 124
- expansion-card riser 2, 126
- fan brackets, 107
- hard drive blank, 85
- hard drive from a drive carrier, 87
- hard drives, 86
- iDRAC6 Enterprise card, 99
- information tag, 82
- integrated storage controller, 113
- internal SD flash card, 94
- internal SD module, 94

- memory modules, 137
- optical drive, 109
- PCIe expansion cards, 123
- power supply, 90
- power supply blank, 92
- processor, 138
- RAID battery, 116
- riser 2 from bracket, 128
- SAS backplane board, 148
- SD card, 95
- system board, 150

replacing

- cooling fan, 106
- expansion-card riser 1, 125
- expansion-card riser 2, 127
- fan brackets, 108
- information tag, 82
- power supply, 91
- system battery, 143

## S

safety, 155

SAS backplane board

- connectors, 183
- installing, 150
- removing, 148

SD card

- installing, 94
- removing, 95
- troubleshooting, 165

SD card (VFlash)

- installing, 100

securing your system, 68, 74

- serial connector, 20
- service-only procedures
  - control panel assembly, 145
  - SAS backplane, 148
  - system board, 150
- setup password, 75
- SSD hard drives, 84
- startup
  - accessing system features, 11
- storage controller
  - cabling for four 3.5-in HDD chassis, 115
  - installing, 113
  - removing, 113
  - troubleshooting, 169
- support
  - contacting Dell, 189
- system board
  - connectors, 180
  - installing, 152
  - jumpers, 177
  - removing, 150
- system cooling
  - troubleshooting, 161
- system features
  - accessing, 11
- system messages, 38
- system password, 73
- system setup program
  - boot settings, 63
  - embedded server management options, 67

- integrated devices options, 64
- keystroke to enter, 58
- main screen, 59
- memory settings, 61
- PCI IRQ assignments, 65
- power management options, 67
- processor settings, 62
- SATA settings, 63
- serial communications
  - options, 66
- system security options, 68

system startup failure, 155

## T

- TPM security, 68
- troubleshooting
  - cooling fans, 162
  - damaged system, 159
  - external connections, 155
  - hard drive, 168
  - internal USB memory key, 166
  - keyboard, 156
  - memory, 163
  - NIC, 157
  - optical drive, 167
  - PCIe expansion cards, 170
  - power supplies, 161
  - processor(s), 172
  - SD card, 165
  - storage controller, 169
  - system battery, 160
  - system cooling, 161
  - system startup failure, 155
  - video, 156

wet system, 158

## U

UEFI Boot Manager

entering, 70

main screen, 71

System Utilities screen, 72

UEFI Boot Settings screen, 72

UEFI boot mode, 57

upgrades

processor, 138

USB

back-panel connectors, 20

front-panel connectors, 12

USB memory key

*See* internal USB memory key.

## V

VFlash media, 100

video

front-panel connectors, 12

troubleshooting, 156

## W

warning messages, 55

warranty, 56

wet system

troubleshooting, 158

